

**BILZ**

# THERMOGRIP® SHRINK FIT TECHNOLOGY



INNOVATION | PERFORMANCE | QUALITY

[www.bilzusa.com](http://www.bilzusa.com)



# BILZ

The Foundation. For over 90 years, Bilz has been a leading supplier of tool holders, tapping technology and shrink fit systems. The main reason for this success is our people. Bilz has over 350 experienced and motivated individuals working every day to improve and enhance the products we offer. Our goal is to improve your manufacturing processes with a complete set of solutions that are efficient and dependable. As a result, we have become an innovative and trusted partner to companies around the world in industries including aerospace, automotive, die mold & machining, medical equipment and power generation.





Dear Reader,

As everyone knows, money is made at the “cutting edge”. The productivity of this cutting edge influences the total costs of cutting processes, while its share of total manufacturing costs amounts to only 4–6%.

Most production and cutting experts will agree with these statements.

What is required to fully profit from the performance of the cutting edge and increase tool life? This catalog will support you in selecting the optimal clamping tools for your “cutting edges”.

Our long experience as a traditional family-run company helps us to develop products you can rely on . Bilz has compiled a comprehensive product range in this catalog. Many improvements have been included.

“Always better” is not just a slogan for us. It is a promise, our commitment to quality. We and our products keep our promises. In addition to this product range we can offer you various custom-designed solutions.

Please talk to us about new solutions for your applications.

Many people react, we act.

On behalf of the whole Bilz Team,

A handwritten signature in black ink, appearing to be "H. Bilz".







# CONTENTS



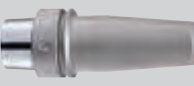

Legend  
page 6

ThermoGrip® Machines – Air Cooled				page 7
				
<b>ISG1000</b> page 10	<b>ISG2200</b> page 11	<b>ISG3430TLK-WS</b> page 12	<b>ISG3430TLK4A-WS</b> page 13	

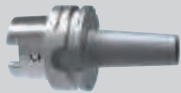

ThermoGrip® Machines – Liquid/Emulsion Cooled			page 8
			
<b>ISG3410TWK-WS</b> page 14	<b>ISG3410WK-WS</b> page 15	<b>ISG4410WK2-HL</b> page 16	

ThermoGrip®  
Accessories  
page 17–23

ThermoGrip® T Series – Standard						page 24
						
<b>HSK-A</b>	<b>HSK-E</b>	<b>HSK-F</b>	<b>CAT</b>	<b>BT</b>	<b>Polygon Shank</b>	
HSK-A40 26 HSK-A50 26 HSK-A63 30–31 HSK-A80 34 HSK-A100 35–36	HSK-E40 27 HSK-E50 28–29	HSK-F63 32–33	CAT40 37–39 Face Contact 38 CAT50 40–41	BT30 42 BT40 43	C6 44–45	



ThermoGrip® TSF Series – SlimLine				page 46
				
<b>HSK-A</b>		<b>HSK-E</b>		<b>HSK-F</b>
HSK-A63	50	HSK-E32	48	HSK-F63
		HSK-E50	49	51
				Extension
				52–53

ThermoGrip® VIDAT		page 54
		
<b>VIDAT</b>		
VIDAT		55

ThermoGrip® THD Series – Heavy Duty				page 56
				
<b>HSK-A</b>		<b>CAT</b>		
HSK-A100	58	CAT40	58	
HSK-A125	59			

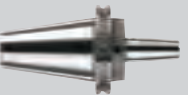
ThermoGrip® TER – Collets		page 60
		
<b>TER</b>		
TER11		62
TER16		62
TER20		62
TER25		62
TER32		62
Accessories		63

ThermoGrip® Corona Jet			page 65
			
<b>HSK-A</b>		<b>HSK-F</b>	<b>CAT</b>
HSK-A63	67	HSK-F63	66
HSK-A100	67	CAT40	65
		CAT50	65

ThermoGrip® JetSleeve®			page 68
			
<b>TJSV</b>		<b>HSK</b>	<b>CAT</b>
Extension		HSK-A63	69
68		CAT40	69
		CAT50	69

MQL	page 70
	
<b>MQL</b>	

ThermoGrip® Hardware	page 72
----------------------	---------

Technical Data	page 75
----------------	---------

## LEGEND



Concentricity of the ThermoGrip® shrink holders

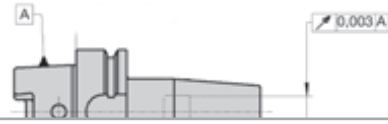

Suitable for the corresponding RPM. You will find more information regarding “Balancing” in the chapter “Technical information”.



With data carrier bore hole



Suitable for internal cooling max. 50 bar



External geometry of the shrink holders. “T” Style holders 4.5° – Slim holders 3°



Corrosion protected-coated



Suitable for deep cavities – especially for the mold and die industry

### Definition ThermoGrip® designations

**T** = ThermoGrip® Standard  
4.5° external geometry

**TSF** = ThermoGrip® slim chucks  
3° external geometry

**TSFV** = ThermoGrip® slim shrink-fit extension  
3° external geometry

**TUS** = ThermoGrip® ultra slim chucks  
3° external geometry

**THD** = ThermoGrip® heavy duty shrink-fit holder  
4.5° external geometry

### The following applies for all ThermoGrip® shrink holders:

Shank tolerance:  $\varnothing 3, 4 = h4 / \varnothing 5 = h5 / \varnothing \geq 6 = h6$

Delivery includes presetting screw

Please order coolant tube separately

MQL version on request

# THERMOGRIP<sup>®</sup> SHRINK FIT MACHINE

## BILZ THERMOGRIP MACHINES

An award-winning line of shrink fit machines, all using the patented Bilz Disc System for optimal machine performance.

ISG1000	Entry level model. No cooling. For tools with a shank size up to 3/4"
ISG2200	Mid level model. Air cooled. For tools with a shank size up to 3/4"
ISG3430TLK	Mid level model. Table top, air cooled. For shank sizes up to 1-1/4"
ISG3430TLK4A	Top level model. Table top, air cooled. For shank sizes up to 1-1/4"
ISG3410TWK	Mid level model. Table top, water cooled. For shank size up to 1-1/4"
ISG3410WK	The "Ultimate" Shrinker. Water cooled. For tools with a shank size up to 2"
ISG4410WK2-HL	Large tool shrinker. Water cooled. For large and heavy shrink fit toolholders.



VIEW  
THE  
DEMO

## THERMOGRIP® MODELS



MACHINE TYPE & FEATURES	<b>ISG100</b> The most-effective, compact starter ALL MANUAL	<b>ISG2100</b> The entry model in the class of inductive shink units AUTOMATIC TIMING	<b>ISG3430TLK</b> The performance class for continual tool changing AUTOMATIC PROGRAMMING	<b>ISG3430TLK4A</b>
Clamping Range SC	3-20mm (1/8"-3/4")	3-20mm (1/8"-3/4")	3-32mm (1/8"-1-1/4")	3-32mm (1/8"-1-1/4")
Clamping Range HSS	N/A	N/A	6-32mm (1/4"-1-1/4")	6-32mm (1/4"-1-1/4")
Coil	Fixed	Fixed	Quick Change	Quick Change
Max. Tool Length	290mm 11.42"	290mm 11.42"	350mm (HSK-A63)	490mm (HSK-A63)
Max. Cooling Length	N/A	200mm 8.0"	350mm 13.77"	350mm 13.77"
Cooling Type	not included – use accessory	air/cooling adapter	air/cooling adapter	air/cooling adapter
Cooling Time	N/A	300 sec	300 sec	300 sec
Geometry Independent Cooling	optional FKS03	optional FKS03	optional FKS04	optional FKS04
Max. Machine Interface	HSK 100 CAT 50	HSK 100 CAT 50	HSK 100 CAT 50	HSK 100 CAT 50
Electric Current Supply	3x208V-15A 3.5 kW	3x208V-15A 3.5 kW	3x480V-16A 11 kW	3x480V-16A 11 kW
Dimensions	390 x 310 x 640mm 15.5" x 12.5" x 25.5"	390 x 310 x 640mm 15.5" x 12.5" x 25.5"	780 x 535 x 950mm 31" x 22" x 38"	800 x 588 x 1018mm 31.5" x 23.5" x 40"
Required Accessories	setting pot cooling adapter external cooling station	setting pot cooling adapter	setting pot cooling adapter	setting pot cooling adapter
Optional Accessories	water cooler air cooler	water cooler air cooler	water cooler	adjusting adapters
For more information	see page 10	see page 11	see page 12	see page 13



## THERMOGRIP® MODELS



<b>ISG3410TWK-WS</b> Lowest cost, liquid-cooled system on the market AUTOMATIC PROGRAMMING	<b>ISG3410WK-WS</b> Free-standing, fully automated system with liquid cooling and air drying	<b>ISG4410WK2-HL</b>	<b>MACHINE TYPE &amp; FEATURES</b>
3-32mm (1/8"-1-1/4")	3-50mm (1/8"-2")	3-50mm (1/8"-2")	Clamping Range SC
6-32mm (1/4"-1-1/4")	6-50mm (1/4"-2")	6-50mm (1/4"-2")	Clamping Range HSS
Quick Change	Quick Change	Quick Change	Coil
400mm 15.75"	680mm 26.77"	750mm 29"	Max. Tool Length
160mm 6.3"	400mm	350mm 13.77"	Max. Cooling Length
liquid/emulsion	liquid/emulsion	liquid/emulsion	Cooling Type
20 sec	20 sec	20 sec	Cooling Time
yes	yes	yes	Geometry Independent Cooling
HSK 100 CAT 50	HSK 100 CAT 50	HSK-A125 CAT 60	Max. Machine Interface
3x480V-16A 11 kW	3x480V-16A 11 kW	3x 480V / 20A 11 kW	Electric Current Supply
800 x 588 x 950mm 31.5" x 23.5" x 38"	800 x 588 x 1950mm 31.5" x 23.5" x 77"	1150 x 770 x 2110mm 45.5" x 30.5" x 83"	Dimensions
setting pot	setting pot	setting pot	Required Accessories
setting pot	#2 coil 32mm-50mm	coils for heavy-wall holders	Optional Accessories
see page 14	see page 15	see page 16	For more information

# ISG3430TLK-WS

TABLE TOP • AIR COOLED



This controlled ISG3400TLK unit is simple to use. All that needs to be done is to select the tool diameter range. After the induction coil is positioned around the tool holder, push the start button and the coil heats the tool holder sufficiently. When heat cycle is completed, move the coil upward away from tool. Press the cooling button and allow the tool to cool in minutes.

## Technical Data: ISG3430TLK-WS

SAP No.	5102055	Max. Tool Length	350 mm 13.77"
Dimensions D x W x H	780mm x 535mm x 950mm 31" x 22" x 38"	Max. Cooling Length	350 mm 13.77"
Clamping Range SC	3mm–32mm 1/8"–1-1/4"	Cooling Type	air/cooling adapter
Clamping Range HSS	6mm–32mm 1/4"–1-1/4"	Cooling Time	300 sec
Coil	Quick Change	Geometry Independent Cooling	optional FKS03
Electric Current Supply	3x480V-16A	Max. Machine Interface	HSK 100 CAT 50
Power kW	11 kW	Required Accessories	setting pot cooling adapter
Weight	100 lbs	Optional Accessories	water cooler



ISG3430TLK4-WS: It is universal shrinking unit for the professional use of shrinking technology. Bilz offers a unique coil changing system, that allows custom coils to be used. Through optimized parameters, the amount of power induced into different clamping chucks assures short cycle times without over-heating. Compared to other systems, the ThermoGrip system makes it possible to clamp even the smallest diameter tools safely and reliably. This allows for a constant preparation of a high number of tools. Guaranteed.

Automated Table top Unit: This controlled ISG3430TLK4-WS unit is simple to use. Only select the tool diameter range, push the start key and the coil moves down automatically to heat the tool holder with the correct amount of power. When the heat cycle is complete, the coil moves up automatically. Place the correct cooling adapter on top of the hot toolholder and slide it to one of the cooling positions to cool in minutes.

The cooling adapters T3-K fit all toolholders that are made to the outer geometry of the DIN69882 standard, e.g. all Bilz ThermoGrip Standard toolholders.

**Technical Data: ISG3430TLK4A-WS**

<b>SAP No.</b>	5099185	<b>Max. Tool Length</b>	490mm (HSK-A63)
<b>Dimensions D x W x H</b>	800 x 588 x 1018mm 31.5" x 23.5" x 40"	<b>Max. Cooling Length</b>	200mm
<b>Clamping Range SC</b>	3-32mm 1/8"-1-1/4"	<b>Cooling Type</b>	air/cooling adapter
<b>Clamping Range HSS</b>	6-32mm 1/4"-1-1/4"	<b>Cooling Time</b>	300 sec
<b>Coil</b>	Quick change system	<b>Geometry Independent Cooling</b>	optional FKS03
<b>Electric Current Supply</b>	3 x 480V / 16A / 50/60Hz	<b>Max. Machine Interface</b>	HSK 100 CAT 50
<b>Power kW</b>	11 kW	<b>Required Accessories</b>	setting pot cooling adapter
<b>Weight</b>	64kg / 141 lbs	<b>Optional Accessories</b>	adjusting adapters

# ISG3410TWK-WS TABLE TOP • WATER COOLED



ISG3410TWK: It is universal shrinking unit for the professional use of shrinking technology. With its unique coil changing system, the amount of power transferred to different clamping chucks is guaranteed within a short period of time. Compared to other systems, this makes it possible to clamp even the smallest diameter tools. This allows for a constant preparation of a high number of tools. Guaranteed.

Universal Table Unit: This controlled ISG3410TWK unit is simple to use. All that needs to be done is to select the tool diameter range. After the induction coil is positioned around the tool holder, push the start button and the coil heats the tool holder appropriately. When heat cycle is completed, move the coil upward away from tool, raise the cooling sleeve and press the cooling button, allowing the tool to cool in seconds.

## Technical Data: ISG3410TWK-WS

SAP No.	5072347	Max. Tool Length	400mm 15.75"
Dimensions D x W x H	800mm x 588mm x 950mm 31.5" x 23.5" x 38"	Max. Cooling Length	160mm 6.3" (at HSK63)
Clamping Range SC	3-32mm 1/8"-1-1/4"	Cooling Type	liquid/emulsion
Clamping Range HSS	6-32mm 1/4"-1-1/4"	Cooling Time	20 sec
Coil	Quick Change	Geometry Independent Cooling	yes
Electric Current Supply	3x480V-16A	Max. Machine Interface	HSK 100 CAT 50
Power kW	11 kW	Required Accessories	setting pot
Weight	93kg / 205 lbs (including coolant)	Optional Accessories	adjusting adapters



ISG3410WK: It is universal shrinking unit for the professional use of shrinking technology. With its unique coil changing system, the power transfer adjusted to different clamping chucks is guaranteed within a short period of time. Compared to other systems, this makes it possible to clamp even the smallest diameter tools. This means that the constant preparation of a high number of tools regardless of size, can be guaranteed.

Free-standing Unit: This controlled ISG3410WK unit is simple to use. All that needs to be done is to select the tool diameter range. Fully automated system allows you to load tool and operate the system almost hands-free. Load diameter of tool, select style of shrink chuck, press the start button and 45 seconds later you tool is installed and cooled to room temperature.

**Technical Data: ISG3410WK-WS**

<b>SAP No.</b>	5072348	<b>Max. Tool Length</b>	700 mm 27.5"
<b>Dimensions D x W x H</b>	800mm x 588mm x 1950mm 31.5" x 23.5" x 77"	<b>Max. Cooling Length</b>	400mm 15.75"
<b>Clamping Range SC</b>	3-50mm (1/8"-2")	<b>Cooling Type</b>	liquid/emulsion
<b>Clamping Range HSS</b>	6-50mm (1/4"-2")	<b>Cooling Time</b>	20 sec
<b>Coil</b>	Quick Change	<b>Geometry Independent Cooling</b>	yes
<b>Electric Current Supply</b>	3x480V-16A	<b>Max. Machine Interface</b>	HSK 100 CAT 50
<b>Power kW</b>	11 kW	<b>Required Accessories</b>	setting pot
<b>Weight</b>	191kg / 421 lbs (including coolant)	<b>Optional Accessories</b>	#2 coil 32mm-50mm

# ISG4410WK2-HL

FREE STANDING • WATER COOLED



The ThermoGrip® ISG4410WK2-HL is a high end unit for the process of shrinking large diameter tools in holders up to HSK-125 including the THD heavy duty thick wall holders.

The ISG4410WK2-HL has been especially designed for heavy roughing tools. Due to the shrinking and cooling positions the process area is accessible from 3 sides, loading and unloading with a lever system is made easy.

With the high weight capacity of 40kg, the cooling process has been designed where the tool stays stationary and the cooling tower raises from the housing surrounding the tool with 360° of coolant.

## Technical Data: ISG4410WK2-HL

SAP No.	5098012	Max. Tool Length	750mm 29"
Dimensions D x W x H	1150mm x 770mm x 2110mm 45.5" x 30.5" x 83"	Max. Cooling Length	500mm 19.6"
Clamping Range SC	3-50mm 1/8"-2"	Cooling Type	liquid/emulsion
Clamping Range HSS	6-50mm 1/4"-2"	Cooling Time	20 sec
Coil	Quick Change	Geometry Independent Cooling	yes
Electric Current Supply	3x 480V / 20A	Max. Machine Interface	HSK 160 CAT 60
Power kW	11 kW	Required Accessories	setting pot
Weight	300kg / 660 lbs	Optional Accessories	coils for heavy-wall holders

**Pole Disc One-Piece**



For optimal shielding of the magnetic field between coil and tool shank.

SAP No.			Designation	Clamping-Ø
ISG1000/ISG2200 208 Volt	ISG1000/ISG2200 400 Volt	ISG3400 Series		
9070801	-	-	ISGS2202-1	3.0 – 5.9 mm
9070800	-	-	ISGS2202-2	6.0 – 12 mm
9070802	-	-	ISGS2202-3	12.1 – 20 mm
-	6725758	-	ISGS2201-1	3.0 – 5.9 mm
-	6725759	-	ISGS2201-2	6.0 – 12 mm
-	6725760	-	ISGS2201-3	12.1 – 20 mm
-	-	6726157	ISGS3201-0	3.0 – 5.9 mm
-	-	6726143	ISGS3201-1	6.0 – 12 mm
-	-	6726144	ISGS3201-2	12.1 – 22 mm
-	-	6726145	ISGS3201-3	22.1 – 32 mm

**Pole Disc Two-Piece**



For use when the cutting diameter is bigger than the shrinking diameter.

SAP No.			Designation	Clamping-Ø
ISG1000	ISG2200 Series	ISG3400 Series		
9074537	9074537	-	ISGS2201GT-1	3.0 – 5.9 mm
9074538	9074538	-	ISGS2201GT-2	6.0 – 12.0 mm
9074539	9074539	-	ISGS2201GT-3	12.1 – 20.0 mm
-	-	9074540	ISGS3201GT-0	3.0 – 5.9 mm
-	-	9074541	ISGS3201GT-1	6.0 – 12.0 mm
-	-	9074542	ISGS3201GT-2	12.1 – 20.0 mm
-	-	9074543	ISGS3201GT-3	20.1 – 32.0 mm

**Pole Disc TSF**



The TSF set allows TSF adaptors to be shrunk using the shrink machine. The TSF discs provide optimal shielding of the magnetic field between coil and tool shank. This guarantees safe and reliable shrinking of the TSF adaptors.

SAP No.			Designation	Clamping-Ø
ISG1000	ISG2200 Series	ISG3400 Series		
9102759	9102759	9102645	ISGS...201-TSF-SET consists of the following parts	
6955194	6955194	6955194	TVP-ISG-TSF storage box	
9102727	9102727	9088924	ISGS...201-TSF03	3 mm
9102728	9102728	9088925	ISGS...201-TSF04	4 mm
9102749	9102749	9102646	ISGS...201-TSF05	5 mm
9102750	9102750	9088926	ISGS...201-TSF06	6 mm
9102752	9102752	9088927	ISGS...201-TSF08	8 mm
9102753	9102753	9088928	ISGS...201-TSF10	10 mm
9102754	9102754	9088980	ISGS...201-TSF12	12 mm
9102755	9102755	9102647	ISGS...201-TSF14	14 mm
9102756	9102756	9088981	ISGS...201-TSF16	16 mm
9102757	9102757	9102648	ISGS...201-TSF18	18 mm
9102758	9102758	9088982	ISGS...201-TSF20	20 mm
-	-	9088983	ISGS3201-TSF25	25 mm

## Tool Holders Water Cooled



For holding and positioning of the shrink chuck on the shrink unit.

SAP No.		Designation
ISG2200WK	ISG3400(T)WK	
9070110	9075293	T..-WWK/HSK25
9206404	9073950	T..-WWK/HSK32-15
9206403	9073952	T..-WWK/HSK40-15
6725777	9073953	T..-WWK/HSK50
6725778	9073954	T..-WWK/HSK63
6725779	9073956	T..-WWK/HSK80
6725780	9073957	T..-WWK/HSK100
9075270	-	T..-WWK/SK25
6725785	9073958	T..-WWK/SK30, CAT30, BT30
9206406	9073959	T..-WWK/SK40-10, CAT40, BT40
6725782	9073961	T..-WWK/SK50, CAT50, BT50
9071851	9079542	T..-WWK/C3
9077794	9076662	T..-WWK/C4
9077795	9076663	T..-WWK/C5
6773336	9076664	T..-WWK/C6
-	9076907	T3-WWK/C8
-	6954754	TGK 301-WWK/100, Extension of tool holders

## Tool Holders Air Cooled



For holding and correct positioning of the shrink chuck on the shrink unit.

SAP No.			Designation
ISG1000	ISG2200	ISG3400TLK	
6725939	6725939	6725939	T3-W/HSK32
6725940	6725940	6725940	T3-W/HSK40
6725941	6725941	6725941	T3-W/HSK50
6725942	6725942	6725942	T3-W/HSK63
6725943	6725943	6725943	T3-W/HSK80
6725938	6725938	6725938	T3-W/HSK100
6725958	6725958	6725958	T3-W/SK30, CAT, BT
6725944	6725944	6725944	T3-W/SK40, CAT, BT
6725945	6725945	6725945	T3-W/SK50, CAT, BT
6725933	6725933	6725933	T3-W/25, ABS25
6725934	6725934	6725934	T3-W/32, ABS32, CAPTO C3
6725935	6725935	6725935	T3-W/40, ABS40, CAPTO C4
6725936	6725936	6725936	T3-W/50, ABS50, CAPTO C5
6725937	6725937	6725937	T3-W/63, ABS63, CAPTO C6
6726048	6726048	6726048	T3-W/SCA1
6726050	6726050	6726050	T3-W/SCA2
6725948	6725948	6725948	T3-W/WE1
6725949	6725949	6725949	T3-W/WE2

All ISG3400WK-WS and ISG3400TWK-WS accessories compatible with accessories from ISG3200WK-WS.

All ISG3400TLK-WS and ISG3400TLK-FS accessories compatible with accessories from ISG3200 air cooled units.



**Cooling Adaptor Air Cooled Unit**



For fast cooling of the heated shrink chucks. Due to the precise design and the enclosure of the clamping area, the heat is rapidly diverted to the outside via the fins of the adaptor.

SAP No.						
ISG1000	ISG2200	ISG2200WK	ISG3200	ISG3200WK	Designation	Clamping-Ø
<b>Projection length up to 120 mm</b>						
6725996	6725996	-	6725996	-	T3-K/3-5.9	3.0-5.9 mm
6725955	6725955	-	6725955	-	T3-K/6-9	6.0-9.0 mm
6725956	6725956	-	6725956	-	T3-K/9.1-12	9.1-12.0 mm
6725951	6725951	-	6725951	-	T3-K/12.1-16	12.1-16.0 mm
6725953	6725953	-	6725953	-	T3-K/16.1-22	16.1-22.0 mm
-	-	-	6725954	-	T3-K/22.1-32	22.1-32.0 mm
<b>Projection length 120-200 mm</b>						
6726049	6726049	-	6726049	-	T3-K/3-5.9, L200	3.0-5.9 mm
6726024	6726024	-	6726024	-	T3-K/6-9, L200	6.0-9.0 mm
6726025	6726025	-	6726025	-	T3-K/9,1-12, L200	9.1-12.0 mm
6726026	6726026	-	6726026	-	T3-K/12,1-16, L200	12.1-16.0 mm
6726027	6726027	-	6726027	-	T3-K/16,1-22, L200	16.1-22.0 mm
-	-	-	6726028	-	T3-K/22,1-32, L200	22.1-32.0 mm

**Cooling Adaptor Blanks**



For fast cooling of the heated shrink chucks. Due to the precise design and the enclosure of the clamping area, the heat is rapidly diverted to the outside via the fins of the adaptor.

SAP No.						
ISG1000	ISG2200	ISG2200WK	ISG3200	ISG3200WK	Designation	Clamping-Ø
6726039	6726039	-	6726039	-	T3-K/0-R	0
6726031	6726031	-	6726031	-	T3-K/18-R	18
6726032	6726032	-	6726032	-	T3-K/35-R	35

## Stop Block



Fixture used for special applications like pole discs two pieces. Used as a stopper for positioning the coil when no correct positioning between pole disc and chuck front end will be possible.

SAP No.					Designation
ISG3200	ISG3200WK	ISG3400TLK-WS	ISG3400TWK-WS	ISG3400WK-WS	
9093048	9093048	-	-	-	ISGF3200.3
-	-	5049287	5049287	5049287	ISGF3414

## Induction Coils



Induction coils for the previous models ISG 3000, ISG 3100, and 3200. Special coils for special applications are available on request.

SAP No.					Designation	Description
ISG3200	ISG3200WK	ISG3400TLK-WS	ISG3400TWK-WS	ISG3400WK-WS		
6726155	6726155	-	-	6726155	ISGS3200-0	small coil
6726141	6726141	6726141	6726141	6726141	ISGS3200-1	standard coil 3-32mm
6726142	6726142	-	-	6726142	ISGS3200-2	large coil 32-50mm
6773722	6773722	6773722	-	6773722	ISGS3200-3.1	inverse coil, 65mm ID
5029693	5029693	5029693	-	5029693	ISGS3200-6	shorter standard coil

## Additional Kit "Inverse"



The additional kit consisting of the special coil, stop block and extension for inverse shrinking of large head diameters.

SAP No.					Designation
ISG3200	ISG3200WK	ISG3400TLS-WS	ISG3400TWK-WS	ISG3400WK-WS	
6773731					ISGS3200-BG2
	9082137				ISGS3200WK-BG1
			5051051	5051051	ISGZ 3400WK-INV
		5051052			ISGZ 3400TLK-INV

**FKS Liquid Cooler**



The liquid cooler is a separate unit for cooling chucks which have been heated up during the shrinking process. With the start-button the cycle cooling and drying runs automatically.

SAP No.	Designation	Dimensions	Air Pressure
6726169	FKS03-450	350mm x 520mm x 220mm	6 bar/87 psi
5052588	FKS3400	424mm x 516mm x 700mm	4 bar/58 psi

**Ejection Device (Shrink Units) for Broken Tools**



The ejection unit enables broken tools to be removed easily from chucks. Even tools where the point of breakage is in the tool holder can be removed without difficulty. The basic tool holder can be adapted to all customary machine interfaces (HSK, SK, ABS) by means of different adaptors. Even with a tight fit (bore diameter/tool shank) the shrunk-in shanks can be removed without difficulty. Further interfaces on request.

SAP No.	Designation
9091116	T3-WSG/HSK32
9091118	T3-WSG/HSK40
9091119	T3-WSG/HSK50
9091120	T3-WSG/HSK63
9091121	T3-WSG/HSK80
9091124	T3-WSG/HSK100
9128634	T3-WSG/SK30
9091127	T3-WSG/SK40
9091128	T3-WSG/SK50

**Modification Set from HSK-63 to . . .**



SAP No.	Designation
9102761	T3-WSG/HSK63-HSK32
9102762	T3-WSG/HSK63-HSK40
5022799	T3-WSG/HSK63-HSK50

**FKS3400 Tool Holders**

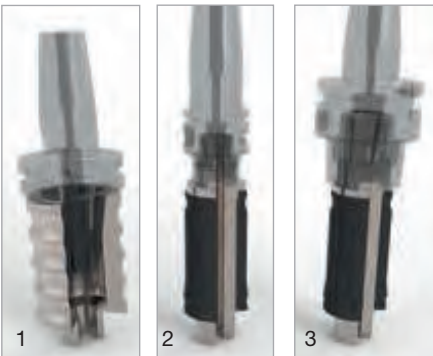

For holding and correct positioning of the shrink chuck on the liquid cooler.

SAP No.	Designation		Image
6773728	FKS03-SK30/40	SK30/40, CAT30/40, BT30/40	1
6773725	FKS03-HSK25/32	HSK-25/32	2
6773725	FKS03-HSK40/50	HSK-40/50/F63	3

## Coolant Emulsion – 5 l



Coolant emulsion for protecting clamping chucks against corrosion. 1 liter bottle.

SAP No.	Designation
5085078	Synergy 905

## Deposit Plate



For safe depositing of pole discs, tool holders and shrunk out tools.

SAP No.					Designation
ISG1000	ISG2200	ISG2200WK	ISG3200	ISG3200WK	
-	-	-	-	9074029	ISG338-BG

## Cooling Plate



For depositing of shrunk out tools.

SAP No.					Designation
ISG1000	ISG2200	ISG2200WK	ISG3200	ISG3200WK	
6726004	6726004	6726004	6726004	6726004	T3-Z/WZ

## Sintered Plate Blanks

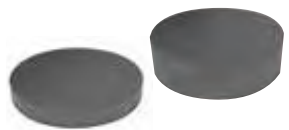

Customization for special sizes.

SAP No.					Designation
ISG1000	ISG2200	ISG2200WK	ISG3200	ISG3200WK	
6706744	6706744	6706744	6706744	6706744	72 x 10.0 R0462301
6706747	6706747	6706747	6706747	6706747	72 x 20.0 R0462309

## Clamping Ring



For secure holding of the pole disc inside the coil.

SAP No.					Designation
ISG1000	ISG2200	ISG2200WK	ISG3200	ISG3200WK	
6950431	6950431	6950431	6950431	6950431	ISGS309

## Protective Gloves



For protection against possible burns and cutting injuries.

SAP No.					Designation
ISG1000	ISG2200	ISG2200WK	ISG3200	ISG3200WK	
6947666	6947666	6947666	6947666	6947666	VA662-10

**Low Price – Big Effect**

The ThermoGrip® measuring adaptor is the low cost entry in presetting and stands out due to its simple handling and versatility. The length in the tool holder can be preset independently of the clamping device.

**One for All**

The ThermoGrip® measuring adaptor works on all standard length presetting units.

**Cost Reduction**

Due to its simplicity handling time, can be saved. The ThermoGrip® measuring adaptor guarantees process security in production due to higher dimensional accuracy at the length presetting.



T3-M... – Metric				
SAP No.	Designation	Dimensions (mm)		
		d <sub>1</sub>	L	SW
6725959	T3-M0600	6	80	2.5
6725962	T3-M0800	8	80	3
6725963	T3-M1000	10	80	4
6726111	T3-M1200	12	80	5
6726112	T3-M1400	14	80	5
6725967	T3-M1600	16	80	6
6725968	T3-M1800	18	80	6
6725969	T3-M2000	20	80	8
6725970	T3-M2500	25	80	8
6725971	T3-M3200	32	80	8

T3-M... – Inch				
SAP No.	Designation	Dimensions (inch)		
		d <sub>1</sub>	L	SW
6725960	T3-M0635	6.35	80	2.5
6726033	T3-M0953	9.525	80	4
6725965	T3-M1270	12.7	80	5
6726088	T3-M1588	15.875	80	6
6726078	T3-M1905	19.05	80	8
6726087	T3-M2223	22.225	80	8
6726079	T3-M2540	25.4	80	8
6726080	T3-M3175	31.75	80	8

**Measurement Process**

The measuring adaptor (B) is put into the ThermoGrip® shrink chuck (A) and locks into the hexagon of the length presetting screw.

The tool (C) is inserted in the measuring adaptor (B).

By turning the measuring adaptor (B) the tool length is determined via the adjusting screw in the chuck with the help of a presetting device.

The measuring adaptor (B) is then taken out of the ThermoGrip® shrink chuck.

The differential dimension (L) (L = 80mm) has to be considered during adjusting. This stored value has to be deducted from the total length.

Tip: Take care not to turn the measuring adaptor (B) when taking it out. Otherwise the length adjusting screw is displaced and the total length is readjusted.

As a last step, put the tool (C) without the measuring adaptor into the counterbore of the ThermoGrip® shrink chuck (A) and shrink it on the ISG unit of your choice.

# THERMOGRIP<sup>®</sup> TOOL HOLDING SYSTEM

## MAKE MORE MONEY AT THE CUTTING EDGE

The ThermoGrip<sup>®</sup> tool holding system uses an inductive heating concept to provide stronger, more-concentric tool clamping. This leads to increased tool life, better surface finishes and improved cost efficiency. Our offering covers machines, holders (including heavy duty), extensions, collets and accessories—everything you need to maximize profits!

- Longest tool life of any holding system
- Highest concentricity (<.003mm)
- Maximum clamping security



VIEW  
THE  
WEBSITE

## T THERMOGRIP® STANDARD

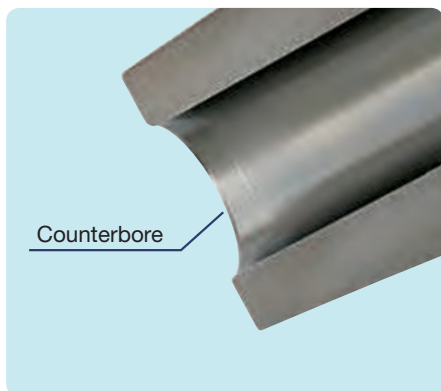

- Precentering of the tool for an automatic shrinking process
- 15%–20% less heat needed during heating – low wear
- Optimal shrinking out of HSS shanks

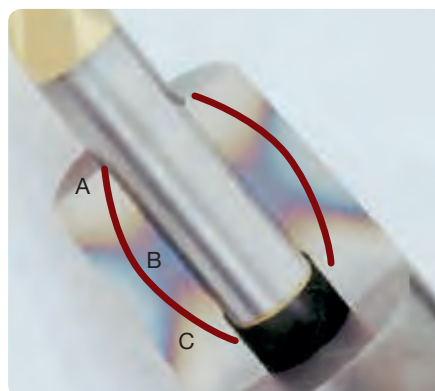

- A - Critical position during release. Cold corners prevent the release of the tool shank
- B - Barrel shaped bore opening (banana effect)
- C - Hot Spot

The picture above shows the cross section of an inductively heated shrink holder. The surface of the chuck mainly heats in the hot spot area very quickly. This area is situated in the middle of the coil spindle. As the temperature is always higher on the surface of the chuck than in the inner part, the chuck opens by micrometres—similar to a banana—slightly outwards. Therefore the chuck is always slightly more open at the hot spot than at the boring entry. The cylindrical counterbore bypasses this critical area securely at reduced energy requirement. Due to this low wear heating process, a longer tool life of the shrink holders is guaranteed.

## MADE IN GERMANY 100%

Optimized stability through “balanced by design” and subsequent fine balancing

- Better surface quality
- Ideal for HPC/HSC processing
- Low wear of the machine spindle

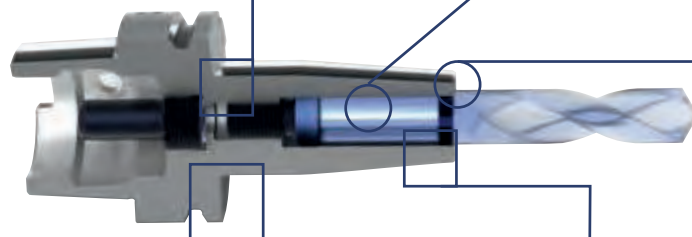

Security

- All standard shanks can be clamped
- No loss of clamping force with greasy and oily shanks

The patented counterbore allows the insertion of the tool under cold condition as well as an automatic shrinking process and simplifies the handling. 15%–20% less heat required when heating the shrink chuck

Longest tool life and form stability due to the use of highly heat resisting special purpose steel

- High radial rigidity
- Low deflection
- High rate of infeeds possible

Highest concentricity

- < 0.003 mm and precise taper tolerances, manufactured in an air-conditioned production area
- Reduced tool costs due to improved tool life, allows constant cutting edge contact
- Reduced chatter marks

## HSK-A40 | ThermoGrip® Standard

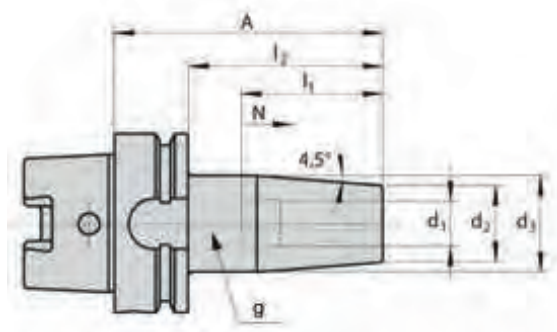

### HSK-A40 – Metric

SAP No.	Designation	Dimensions (mm)						
		$d_1$	A	$d_2$	$d_3$	$l_1$	N	g
<b>STANDARD PROJECTION</b>								
6726615	T0300-60/HSK-A40	3	60	15	21	20	5	M6
6726616	T0400-60/HSK-A40	4	60	15	21	20	5	M6
6726617	T0500-60/HSK-A40	5	60	15	21	25	5	M6
6726222	T0600-80/HSK-A40	6	80	21	27	36	10	M5
6726223	T0800-80/HSK-A40	8	80	21	27	36	10	M6
6726224	T1000-80/HSK-A40	10	80	24	32	42	10	M8x1
6726225	T1200-90/HSK-A40	12	90	24	32	47	10	M10x1
6726226	T1400-90/HSK-A40	14	90	27	34	47	10	M10x1
6726227	T1600-90/HSK-A40	16	90	27	34	50	10	M12x1

All holders can be run with internal coolant

Please Order Coolant Tube Catalog No. HSK40-12 separately

NOTE: Tool Shank Tolerance must be h6 or better, h4 for holders with ID smaller than 5mm

## HSK-A50 | ThermoGrip® Standard



### HSK-A50 – Metric

SAP No.	Designation	Dimensions (mm)						
		$d_1$	A	$d_2$	$d_3$	$l_1$	N	g
<b>STANDARD PROJECTION</b>								
5038902	T0300-80/HSK-A50	3	80	15	21	20	5	M6
9179308	T0400-80/HSK-A50	4	80	15	21	20	5	M6
5000253	T0500-80/HSK-A50	5	80	15	21	25	5	M6
6726232	T0600-80/HSK-A50	6	80	21	27	36	10	M5
6726233	T0800-80/HSK-A50	8	80	21	27	36	10	M6
6726234	T1000-85/HSK-A50	10	85	24	32	42	10	M8x1
6726235	T1200-90/HSK-A50	12	90	24	32	47	10	M10x1
6726236	T1400-90/HSK-A50	14	90	27	34	47	10	M10x1
6726237	T1600-95/HSK-A50	16	95	27	34	50	10	M12x1
6726238	T1800-95/HSK-A50	18	95	33	42	50	10	M12x1
6726239	T2000-100/HSK-A50	20	100	33	42	52	10	M16x1

All holders can be run with internal coolant

Please Order Coolant Tube Catalog No. HSK50-16 separately

NOTE: Tool Shank Tolerance must be h6 or better, h4 for holders with ID smaller than 5mm



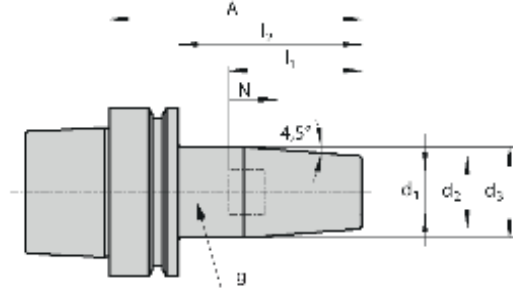

**HSK-E40 – Inch**

SAP No.	Designation	Dimensions (inch)						
		$d_1$	A	$d_2$	$d_3$	$l_1$	N	g
<b>STANDARD PROJECTION</b>								
9079262	T0318-60/HSK-E40	0.125	2.36	0.83	1.06	1.42	0.39	M6
9079269	T0476-60/HSK-E40	0.187	2.36	0.83	1.06	1.42	0.39	M6
9079208	T0635-80/HSK-E40	0.250	3.15	0.83	1.06	1.42	0.39	M5
9079215	T0953-80/HSK-E40	0.375	3.15	0.95	1.26	1.65	0.39	M8x1
9079243	T1270-90/HSK-E40	0.500	3.54	1.06	1.34	1.85	0.39	M10x1
9079248	T1588-90/HSK-E40	0.625	3.54	1.06	1.34	1.97	0.39	M12x1
<b>LONG PROJECTION</b>								
9079263	T0318-120/HSK-E40	0.125	4.72	0.83	1.06	1.42	0.39	M6
9079270	T0476-120/HSK-E40	0.187	4.72	0.83	1.06	1.42	0.39	M6
9079210	T0635-120/HSK-E40	0.250	4.72	0.83	1.06	1.42	0.39	M5
9079216	T0953-120/HSK-E40	0.375	4.72	0.95	1.26	1.65	0.39	M8x1
9079244	T1270-120/HSK-E40	0.500	4.72	1.06	1.34	1.85	0.39	M10x1
9079249	T1588-120/HSK-E40	0.625	4.72	1.06	1.34	1.97	0.39	M12x1

All holders can be run with internal coolant

NOTE: Tool Shank Tolerance must be h6 or better, h4 for holders with ID smaller than 5mm

**HSK-E40 – Metric**

SAP No.	Designation	Dimensions (mm)						
		$d_1$	A	$d_2$	$d_3$	$l_1$	N	g
<b>STANDARD PROJECTION</b>								
6726576	T0300-60/HSK-E40	3	60	15	21	20	5	M6
6726577	T0400-60/HSK-E40	4	60	15	21	20	5	M6
6726578	T0500-60/HSK-E40	5	60	15	21	25	5	M6
6726299	T0600-80/HSK-E40	6	80	21	27	36	10	M5
6726300	T0800-80/HSK-E40	8	80	21	27	36	10	M6
6726301	T1000-80/HSK-E40	10	80	24	32	42	10	M8x1
6726302	T1200-90/HSK-E40	12	90	24	32	47	10	M10x1
6726303	T1400-90/HSK-E40	14	90	27	34	47	10	M10x1
6726304	T1600-90/HSK-E40	16	90	27	34	50	10	M12x1
<b>LONG PROJECTION</b>								
6726989	T0600-120/HSK-E40	6	120	21	27	36	10	M5
6726990	T0800-120/HSK-E40	8	120	21	27	36	10	M6
6726991	T1000-120/HSK-E40	10	120	24	32	42	10	M8x1
6726992	T1200-120/HSK-E40	12	120	24	32	47	10	M10x1
6726993	T1400-120/HSK-E40	14	120	27	34	47	10	M10x1
6726994	T1600-120/HSK-E40	16	120	27	34	50	10	M12x1

All holders can be run with internal coolant

NOTE: Tool Shank Tolerance must be h6 or better, h4 for holders with ID smaller than 5mm

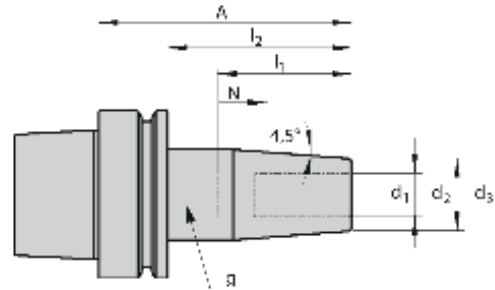

## HSK-E50 – Inch

SAP No.	Designation	Dimensions (inch)						
		d <sub>1</sub>	A	d <sub>2</sub>	d <sub>3</sub>	l <sub>1</sub>	N	g
<b>STANDARD PROJECTION</b>								
9079264	T0318-80/HSK-E50	0.125	3.15	0.83	1.06	1.42	0.39	M6
9079271	T0476-80/HSK-E50	0.187	3.15	0.83	1.06	1.42	0.39	M6
6727386	T0635-80/HSK-E50	0.250	3.15	0.83	1.06	1.42	0.39	M5
6727388	T0953-85/HSK-E50	0.375	3.34	0.95	1.26	1.65	0.39	M8x1
6727390	T1270-90/HSK-E50	0.500	3.54	1.06	1.34	1.85	0.39	M10x1
9079250	T1588-95/HSK-E50	0.625	3.74	1.06	1.34	1.97	0.39	M12x1
9079256	T1905-100/HSK-E50	0.750	3.94	1.30	1.65	2.05	0.39	M16x1
<b>LONG PROJECTION</b>								
9079265	T0318-160/HSK-E50	0.125	6.30	0.83	1.26	1.42	0.39	M6
9079272	T0476-160/HSK-E50	0.187	6.30	0.83	1.26	1.42	0.39	M6
9079211	T0635-160/HSK-E50	0.250	6.30	0.83	1.26	1.42	0.39	M5
9079218	T0953-160/HSK-E50	0.375	6.30	0.95	1.34	1.65	0.39	M8x1
9079245	T1270-160/HSK-E50	0.500	6.30	1.06	1.65	1.85	0.39	M10x1
9079252	T1588-160/HSK-E50	0.625	6.30	1.06	1.65	1.97	0.39	M12x1
9079257	T1905-160/HSK-E50	0.750	6.30	1.30	2.01	2.05	0.39	M16x1

All holders can be run with internal coolant

NOTE: Tool Shank Tolerance must be h6 or better, h4 for holders with ID smaller than 5mm

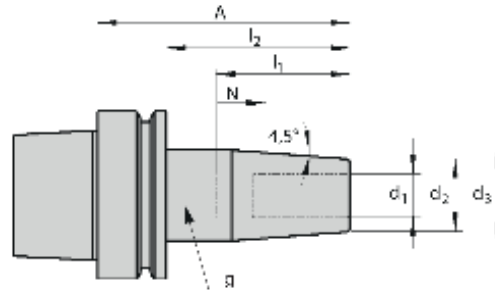

HSK-E50 – Metric								
SAP No.	Designation	Dimensions (mm)						
		$d_1$	A	$d_2$	$d_3$	$l_1$	N	g
<b>STANDARD PROJECTION</b>								
6726654	T0300-80/HSK-E50	3	80	15	21	20	5	M6
6726655	T0400-80/HSK-E50	4	80	15	21	20	5	M6
6726656	T0500-80/HSK-E50	5	80	15	21	25	5	M6
6726309	T0600-80/HSK-E50	6	80	21	27	36	10	M5
6726310	T0800-80/HSK-E50	8	80	21	27	36	10	M6
6726311	T1000-85/HSK-E50	10	85	24	32	42	10	M8x1
6726312	T1200-90/HSK-E50	12	90	24	32	47	10	M10x1
6726313	T1400-90/HSK-E50	14	90	27	34	47	10	M10x1
6726314	T1600-95/HSK-E50	16	95	27	34	50	10	M12x1
6726315	T1800-95/HSK-E50	18	95	33	42	50	10	M12x1
6726316	T2000-100/HSK-E50	20	100	33	42	52	10	M16x1
<b>LONG PROJECTION</b>								
6726888	T0600-120/HSK-E50	6	120	21	27	36	10	M5
6726891	T0800-120/HSK-E50	8	120	21	27	36	10	M6
6726756	T1000-120/HSK-E50	10	120	24	32	42	10	M8x1
6726896	T1200-120/HSK-E50	12	120	24	32	47	10	M10x1
6726899	T1400-120/HSK-E50	14	120	27	34	47	10	M10x1
6726964	T1600-120/HSK-E50	16	120	27	34	50	10	M12x1
6726965	T1800-120/HSK-E50	18	120	33	42	50	10	M12x1
6726966	T2000-120/HSK-E50	20	120	33	42	52	10	M16x1
<b>EXTRA LONG PROJECTION</b>								
6726889	T0600-160/HSK-E50	6	160	21	32	36	10	M5
6726892	T0800-160/HSK-E50	8	160	21	32	36	10	M6
6726894	T1000-160/HSK-E50	10	160	24	34	42	10	M8x1
6726897	T1200-160/HSK-E50	12	160	24	34	47	10	M10x1
6726900	T1400-160/HSK-E50	14	160	27	42	47	10	M10x1
6726902	T1600-160/HSK-E50	16	160	27	42	50	10	M12x1
6726904	T1800-160/HSK-E50	18	160	33	51	50	10	M12x1
6726906	T2000-160/HSK-E50	20	160	33	51	52	10	M16x1

All holders can be run with internal coolant

NOTE: Tool Shank Tolerance must be h6 or better, h4 for holders with ID smaller than 5mm

## HSK-A63 | ThermoGrip® Standard

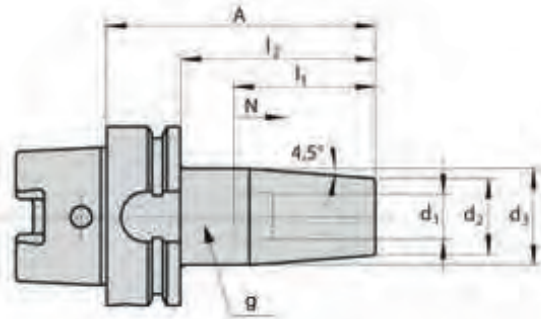
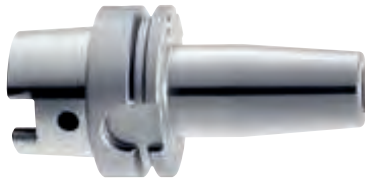

## HSK-A63 – Inch

SAP No.	Designation	Dimensions (inch)						
		$d_1$	A	$d_2$	$d_3$	$l_1$	N	g
<b>STANDARD PROJECTION</b>								
9079266	T0318-80/HSK-A63	0.125	3.15	0.83	1.06	1.42	0.39	M6
9079278	T0476-80/HSK-A63	0.187	3.15	0.83	1.06	1.42	0.39	M6
6726420	T0635-80/HSK-A63	0.250	3.15	0.83	1.06	1.42	0.39	M5
6726422	T0953-85/HSK-A63	0.375	3.34	0.95	1.26	1.65	0.39	M8x1
6726424	T1270-90/HSK-A63	0.500	3.54	1.06	1.34	1.85	0.39	M10x1
6726426	T1588-95/HSK-A63	0.625	3.74	1.06	1.34	1.97	0.39	M12x1
6726428	T1905-100/HSK-A63	0.750	3.94	1.30	1.65	2.05	0.39	M16x1
<b>LONG PROJECTION</b>								
9079267	T0318-120/HSK-A63	0.125	4.72	0.83	1.06	1.42	0.39	M6
9079279	T0476-120/HSK-A63	0.187	4.72	0.83	1.06	1.42	0.39	M6
6727392	T0635-120/HSK-A63	0.250	4.72	0.83	1.06	1.42	0.39	M5
6727393	T0953-120/HSK-A63	0.375	4.72	0.95	1.26	1.65	0.39	M8x1
6727394	T1270-120/HSK-A63	0.500	4.72	1.06	1.34	1.85	0.39	M10x1
9079254	T1588-120/HSK-A63	0.625	4.72	1.06	1.34	1.97	0.39	M12x1
6726430	T2540-120/HSK-A63	1.000	4.72	1.73	2.09	2.44	0.39	M16x1
6726431	T3175-120/HSK-A63	1.250	4.72	1.73	2.09	2.28	0.39	M16x1
<b>EXTRA LONG PROJECTION</b>								
9079268	T0318-160/HSK-A63	0.125	6.30	0.83	1.26	1.42	0.39	M6
9079280	T0476-160/HSK-A63	0.187	6.30	0.83	1.26	1.42	0.39	M6
6726614	T0635-160/HSK-A63	0.250	6.30	0.83	1.26	1.42	0.39	M5
9079221	T0953-160/HSK-A63	0.375	6.30	0.95	1.34	1.65	0.39	M8x1
9079247	T1270-160/HSK-A63	0.500	6.30	1.06	1.65	1.85	0.39	M10x1
9079255	T1588-160/HSK-A63	0.625	6.30	1.06	1.65	1.97	0.39	M12x1
9079258	T1905-160/HSK-A63	0.750	6.30	1.30	2.01	2.05	0.39	M16x1
9079259	T2540-160/HSK-A63	1.000	6.30	1.73	2.09	2.44	0.39	M16x1
9079261	T3175-160/HSK-A63	1.250	6.30	1.73	2.09	2.28	0.39	M16x1

All holders can be run with internal coolant

Please Order Coolant Tube Catalog No. HSK63-18 separately

NOTE: Tool Shank Tolerance must be h6 or better, h4 for holders with ID smaller than 5mm

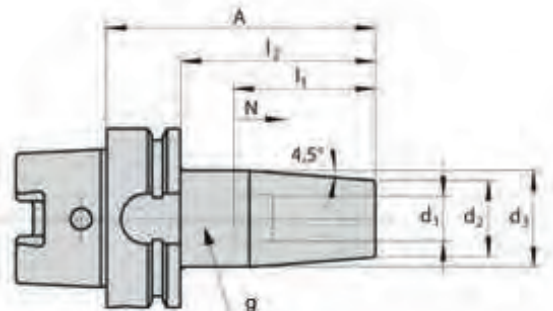

HSK-A63 – Metric								
SAP No.	Designation	Dimensions (mm)						
		$d_1$	A	$d_2$	$d_3$	$l_1$	N	g
<b>STANDARD PROJECTION</b>								
6726618	T0300-80/HSK-A63	3	80	15	20	20	5	M6
6726619	T0400-80/HSK-A63	4	80	15	20	20	5	M6
6726620	T0500-80/HSK-A63	5	80	15	20	25	5	M6
6726201	T0600-80/HSK-A63	6	80	21	27	36	10	M5
6726202	T0800-80/HSK-A63	8	80	21	27	36	10	M6
6726203	T1000-85/HSK-A63	10	85	24	32	42	10	M8x1
6726204	T1200-90/HSK-A63	12	90	24	32	47	10	M10x1
6726205	T1400-90/HSK-A63	14	90	27	34	47	10	M10x1
6726206	T1600-95/HSK-A63	16	95	27	34	50	10	M12x1
6726211	T1800-95/HSK-A63	18	95	33	42	50	10	M12x1
6726207	T2000-100/HSK-A63	20	100	33	42	52	10	M16x1
6726208	T2500-115/HSK-A63	25	115	44	53	58	10	M16x1
<b>LONG PROJECTION</b>								
6726388	T0600-120/HSK-A63	6	120	21	27	36	10	M5
6726391	T0800-120/HSK-A63	8	120	21	27	36	10	M6
6726392	T1000-120/HSK-A63	10	120	24	32	42	10	M8x1
6726410	T1200-120/HSK-A63	12	120	24	32	47	10	M10x1
6726401	T1400-120/HSK-A63	14	120	27	34	47	10	M10x1
6726399	T1600-120/HSK-A63	16	120	27	34	50	10	M12x1
6726539	T1800-120/HSK-A63	18	120	33	42	50	10	M12x1
6726662	T2000-120/HSK-A63	20	120	33	42	52	10	M16x1
6726209	T3200-120/HSK-A63	32	120	44	53	58	10	M16x1
<b>EXTRA LONG PROJECTION</b>								
6726411	T0600-160/HSK-A63	6	160	21	32	36	10	M5
6726402	T0800-160/HSK-A63	8	160	21	32	36	10	M6
6726403	T1000-160/HSK-A63	10	160	24	34	42	10	M8x1
6726404	T1200-160/HSK-A63	12	160	24	34	47	10	M10x1
6726405	T1400-160/HSK-A63	14	160	27	42	47	10	M10x1
6726406	T1600-160/HSK-A63	16	160	27	42	50	10	M12x1
6726407	T1800-160/HSK-A63	18	160	33	51	50	10	M12x1
6726468	T2000-160/HSK-A63	20	160	33	51	52	10	M16x1
6726408	T2500-160/HSK-A63	25	160	44	53	58	10	M16x1
6726409	T3200-160/HSK-A63	32	160	44	53	62	10	M16x1

All holders can be run with internal coolant  
 Please Order Coolant Tube Catalog No. HSK63-18 separately  
 NOTE: Tool Shank Tolerance must be h6 or better, h4 for holders with ID smaller than 5mm

## HSK-F63 | ThermoGrip® Standard

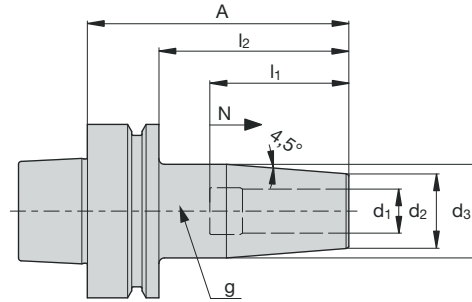

## HSK-F63 – Inch

SAP No.	Designation	Dimensions (inch)							
		d <sub>1</sub>	A	l <sub>2</sub>	d <sub>2</sub>	d <sub>3</sub>	l <sub>1</sub>	N	g
<b>STANDARD PROJECTION</b>									
5057126	T0635-90/HSK-F63	0.250	3.54	2.52	0.83	1.06	1.42	0.39	M5
5057131	T0953-90/HSK-F63	0.375	3.54	2.52	0.95	1.26	1.65	0.39	M8x1
5057133	T1270-90/HSK-F63	0.500	3.74	2.52	1.06	1.34	1.85	0.39	M10x1
5057140	T1588-95/HSK-F63	0.625	3.74	2.72	1.06	1.34	1.97	0.39	M12x1
5057142	T1905-100/HSK-F63	0.750	3.94	2.91	1.30	1.65	2.05	0.39	M16x1
5057148	T2540-115/HSK-F63	1.000	4.53	3.50	1.73	2.09	2.44	0.39	M16x1

All holders can be run with internal coolant

NOTE: Tool Shank Tolerance must be h6 or better, h4 for holders with ID smaller than 5mm

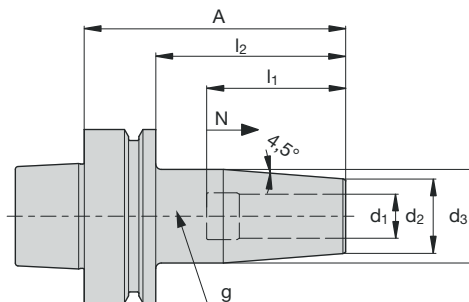

HSK-F63 – Metric									
SAP No.	Designation	Dimensions (mm)							
		$d_1$	A	$l_2$	$d_2$	$d_3$	$l_1$	N	g
<b>STANDARD PROJECTION</b>									
9107682	T0300/HSK-F63	3	90	64	15	20	20	5	M6
6773733	T0400/HSK-F63	4	90	64	15	20	20	5	M6
9091580	T0500/HSK-F63	5	90	64	15	20	25	5	M6
9122311	T0600-90/HSK-F63	6	90	64	20	27	36	10	M5
9122312	T0800-90/HSK-F63	8	90	64	21	27	36	10	M6
6726373	T1000/HSK-F63	10	90	64	24	32	42	10	M8x1
6726374	T1200/HSK-F63	12	95	69	24	32	47	10	M10x1
6726393	T1400/HSK-F63	14	95	69	27	34	47	10	M10x1
6726414	T1600/HSK-F63	16	95	69	27	34	50	10	M12x1
6726415	T1800/HSK-F63	18	95	69	33	42	50	10	M12x1
6726375	T2000/HSK-F63	20	100	74	33	42	52	10	M16x1
6727436	T2500/HSK-F63	25	115	89	44	53	58	10	M16x1
<b>LONG PROJECTION</b>									
9115118	T0300-120/HSK-F63	3	120	94	15	20	20	5	M6
9115149	T0400-120/HSK-F63	4	120	94	15	20	20	5	M6
9115150	T0500-120/HSK-F63	5	120	94	15	20	25	5	M6
9075284	T0600-120/HSK-F63	6	120	94	21	27	36	10	M5
6726841	T0800-120/HSK-F63	8	120	94	21	27	36	10	M6
6727435	T1000-120/HSK-F63	10	120	94	24	32	42	10	M8x1
6726810	T1200-120/HSK-F63	12	120	94	24	32	47	10	M10x1
9115151	T1400-120/HSK-F63	14	120	94	27	34	47	10	M10x1
9077033	T1600-120/HSK-F63	16	120	94	27	34	50	10	M12x1
9115152	T1800-120/HSK-F63	18	120	94	33	42	50	10	M12x1
9115153	T2000-120/HSK-F63	20	120	94	33	42	52	10	M16x1
<b>EXTRA LONG PROJECTION</b>									
9115154	T0300-160/HSK-F63	3	160	134	15	27	20	5	M6
9115155	T0400-160/HSK-F63	4	160	134	15	27	20	5	M6
9115156	T0500-160/HSK-F63	5	160	134	15	27	25	5	M6
9115158	T0600-160/HSK-F63	6	160	134	21	32	36	10	M5
9080135	T0800-160/HSK-F63	8	160	134	21	32	36	10	M6
9080136	T1000-160/HSK-F63	10	160	134	24	34	42	10	M8x1
6727465	T1200-160/HSK-F63	12	160	134	24	34	47	10	M10x1
9115160	T1400-160/HSK-F63	14	160	134	27	42	47	10	M10x1
9097804	T1600-160/HSK-F63	16	160	134	27	42	50	10	M12x1
9115162	T1800-160/HSK-F63	18	160	134	33	51	50	10	M12x1
9075282	T2000-160/HSK-F63	20	160	134	33	51	52	10	M16x1

All holders can be run with internal coolant

NOTE: Tool Shank Tolerance must be h6 or better, h4 for holders with ID smaller than 5mm

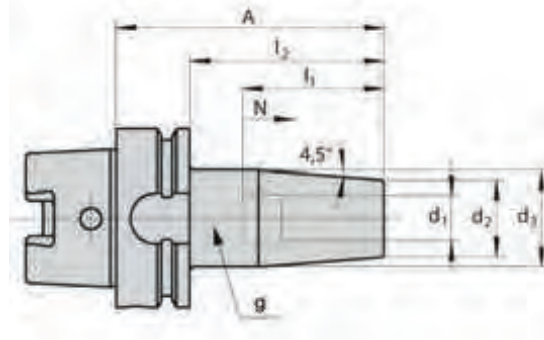

## HSK-A80 – Metric

SAP No.	Designation	Dimensions (mm)							
		$d_1$	A	$l_2$	$d_2$	$d_3$	$l_1$	N	g
<b>STANDARD PROJECTION</b>									
6726455	T0600/HSK-A80	6	85	59	21	27	36	10	M5
6726396	T0800/HSK-A80	8	85	59	21	27	36	10	M6
6726985	T1000/HSK-A80	10	90	64	24	32	42	10	M8x1
6726397	T1200/HSK-A80	12	95	69	24	32	47	10	M10x1
6727004	T1400/HSK-A80	14	95	69	27	34	47	10	M10x1
6726658	T1600/HSK-A80	16	100	74	27	34	50	10	M12x1
6726874	T1800/HSK-A80	18	100	74	33	42	50	10	M12x1
6726659	T2000/HSK-A80	20	105	79	33	42	52	10	M16x1
6726488	T2500/HSK-A80	25	115	89	44	53	58	10	M16x1
6726882	T3200/HSK-A80	32	120	94	44	53	62	10	M16x1

All holders can be run with internal coolant

Please Order Coolant Tube Catalog No. HSK80-18 separately

NOTE: Tool Shank Tolerance must be h6 or better, h4 for holders with ID smaller than 5mm



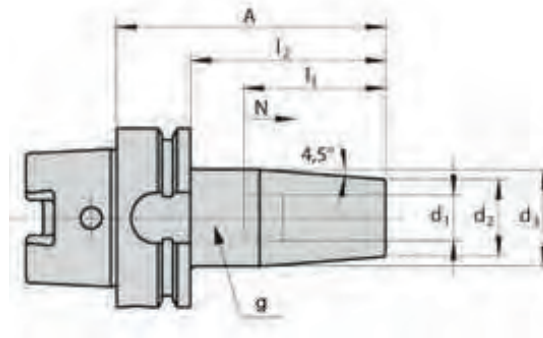

HSK-A100 – Inch								
SAP No.	Designation	Dimensions (inch)						
		$d_1$	A	$d_2$	$d_3$	$l_1$	N	g
<b>STANDARD PROJECTION</b>								
6726432	T0635-85/HSK-A100	0.250	3.35	0.83	1.06	1.42	0.39	M5
6726434	T0953-90/HSK-A100	0.375	3.54	0.94	1.26	1.65	0.39	M8X1
6726436	T1270-95/HSK-A100	0.500	3.74	1.06	1.34	1.85	0.39	M10X1
6726438	T1588-95/HSK-A100	0.625	3.94	1.06	1.34	1.97	0.39	M12X1
6726497	T1905-105/HSK-A100	0.750	4.13	1.30	1.65	2.05	0.39	M16X1
6726442	T2540-120/HSK-A100	1.000	4.72	1.73	2.09	2.44	0.39	M16X1
6726444	T3175-120/HSK-A100	1.250	4.72	1.73	2.09	2.44	0.39	M16X1
<b>EXTRA LONG PROJECTION</b>								
5057075	T0635-160/HSK-A100	0.250	6.30	0.83	1.26	1.42	0.39	M5
5057077	T0953-160/HSK-A100	0.375	6.30	0.94	1.34	1.65	0.39	M8X1
5057080	T1270-160/HSK-A100	0.500	6.30	1.06	1.65	1.85	0.39	M10X1
5057082	T1588-160/HSK-A100	0.625	6.30	1.06	1.65	1.97	0.39	M12X1
5057084	T1905-160/HSK-A100	0.750	6.30	1.30	2.01	2.05	0.39	M16X1
5057093	T2540-160/HSK-A100	1.000	6.30	1.73	2.36	2.44	0.39	M16X1

All holders can be run with internal coolant

Please Order Coolant Tube Catalog No. HSK100-24 separately

NOTE: Tool Shank Tolerance must be h6 or better, h4 for holders with ID smaller than 5mm

\*Non-stocked items Price on application

## HSK-A100 | ThermoGrip® Standard

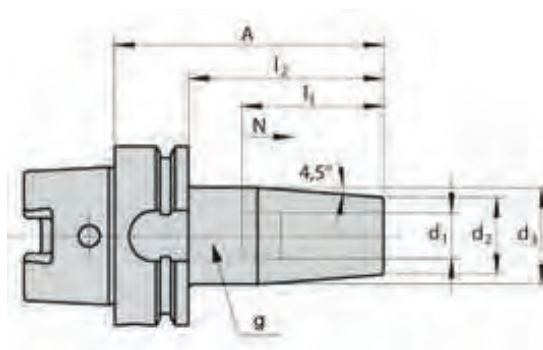

## HSK-A100 – Metric

SAP No.	Designation	Dimensions (mm)						
		$d_1$	A	$d_2$	$d_3$	$l_1$	N	g
<b>STANDARD PROJECTION</b>								
6726342	T0600-85/HSK-A100	6	85	21	27	36	10	M5
6726343	T0800-85/HSK-A100	8	85	21	27	36	10	M6
6726344	T1000-90/HSK-A100	10	90	24	32	42	10	M8x1
6726345	T1200-95/HSK-A100	12	95	24	32	47	10	M10x1
6726346	T1400-95/HSK-A100	14	95	27	34	50	10	M10x1
6726347	T1600-100/HSK-A100	16	100	27	34	50	10	M12x1
6726348	T1800-100/HSK-A100	18	100	33	42	50	10	M12x1
6726349	T2000-105/HSK-A100	20	105	33	42	52	10	M16x1
6726350	T2500-115/HSK-A100	25	115	44	53	58	10	M16x1
<b>LONG PROJECTION</b>								
6726478	T0600-120/HSK-A100	6	120	21	27	36	10	M5
6726479	T0800-120/HSK-A100	8	120	21	27	36	10	M6
6726755	T1000-120/HSK-A100	10	120	24	32	42	10	M8x1
6726480	T1200-120/HSK-A100	12	120	24	32	47	10	M10x1
6726833	T1400-120/HSK-A100	14	120	27	34	50	10	M10x1
6726820	T1600-120/HSK-A100	16	120	27	34	50	10	M12x1
6727035	T1800-120/HSK-A100	18	120	33	42	50	10	M12x1
6726821	T2000-120/HSK-A100	20	120	33	42	52	10	M16x1
6727037	T2500-120/HSK-A100	25	120	44	53	58	10	M16x1
6726351	T3200-120/HSK-A100	32	120	44	53	62	10	M16x1
<b>EXTRA LONG PROJECTION</b>								
6726645	T0600-160/HSK-A100	6	160	21	32	36	10	M5
6726646	T0800-160/HSK-A100	8	160	21	32	36	10	M6
6726647	T1000-160/HSK-A100	10	160	24	34	42	10	M8x1
6726648	T1200-160/HSK-A100	12	160	24	34	47	10	M10x1
6726649	T1400-160/HSK-A100	14	160	27	42	47	10	M10x1
6726650	T1600-160/HSK-A100	16	160	27	42	50	10	M12x1
6727036	T1800-160/HSK-A100	18	160	33	51	52	10	M12x1
6726643	T2000-160/HSK-A100	20	160	33	51	52	10	M16x1
6726644	T2500-160/HSK-A100	25	160	44	60	58	10	M16x1
6727038	T3200-160/HSK-A100	32	160	44	60	62	10	M16x1

All holders can be run with internal coolant

Please Order Coolant Tube Catalog No. HSK100-24 separately

NOTE: Tool Shank Tolerance must be h6 or better, h4 for holders with ID smaller than 5mm

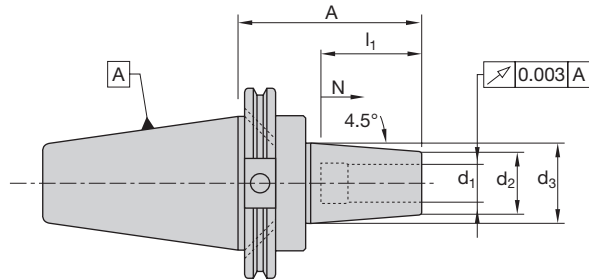

CAT40 – Inch								
SAP No.	Designation	Dimensions (inch)						
		$d_1$	A	$d_2$	$d_3$	$l_1$	N	g
<b>STANDARD PROJECTION</b>								
9087264	T0318-95/CAT-40	0.125	3.74	0.59	0.79	0.79	0.20	M6
9087265	T0476-95/CAT-40	0.187	3.74	0.59	0.79	0.79	0.20	M6
9075136	T0635-95/CAT-40	0.250	3.74	0.83	1.06	1.42	0.39	M5
9074678	T0953-95/CAT-40	0.375	3.74	0.95	1.26	1.65	0.39	M8x1
9074679	T1270-95/CAT-40	0.500	3.74	1.06	1.34	1.85	0.39	M10x1
9074680	T1588-95/CAT-40	0.625	3.74	1.06	1.34	1.97	0.39	M12x1
9074681	T1905-95/CAT-40	0.750	3.74	1.30	1.65	2.05	0.39	M16x1
9074675	T2540-100/CAT-40	1.000	3.94	1.73	2.09	2.44	0.39	M16x1
9074647	T3175-100/CAT-40	1.250	3.94	1.73	2.09	2.44	0.39	M16x1
<b>LONG PROJECTION</b>								
9087267	T0318-120/CAT-40	0.125	4.73	0.59	0.79	0.79	0.20	M6
9087268	T0476-120/CAT-40	0.187	4.73	0.59	0.79	0.79	0.20	M6
9074633	T0635-120/CAT-40	0.250	4.73	0.83	1.06	1.42	0.39	M5
9074635	T0953-120/CAT-40	0.375	4.73	0.95	1.26	1.65	0.39	M8x1
9074637	T1270-120/CAT-40	0.500	4.73	1.06	1.34	1.85	0.39	M10x1
9074639	T1588-120/CAT-40	0.625	4.73	1.06	1.34	1.97	0.39	M12x1
9074641	T1905-120/CAT-40	0.750	4.73	1.30	1.65	2.05	0.39	M16x1
9074645	T2540-120/CAT-40	1.000	4.73	1.73	2.09	2.44	0.39	M16x1
9074648	T3175-120/CAT-40	1.25	4.73	1.73	2.09	2.44	0.39	M16x1
<b>EXTRA LONG PROJECTION</b>								
9087270	T0318-160/CAT-40	0.125	6.30	0.59	0.79	0.79	0.20	M6
9087271	T0476-160/CAT-40	0.187	6.30	0.59	0.79	0.79	0.20	M6
9074634	T0635-160/CAT-40	0.250	6.30	0.83	1.26	1.42	0.39	M5
9074636	T0953-160/CAT-40	0.375	6.30	0.95	1.34	1.65	0.39	M8x1
9074638	T1270-160/CAT-40	0.500	6.30	1.06	1.65	1.85	0.39	M10x1
9074640	T1588-160/CAT-40	0.625	6.30	1.06	1.65	1.97	0.39	M12x1
9074642	T1905-160/CAT-40	0.750	6.30	1.30	1.75	2.05	0.39	M16x1
9074646	T2540-160/CAT-40	1.000	6.30	1.73	2.09	2.44	0.39	M16x1
9074649	T3175-160/CAT-40	1.250	6.30	1.73	2.09	2.44	0.39	M16x1

NOTE: All Holders Have 5/8-11 UNC Thread for Retention Knob & DIN FORM B Flange Coolant Delivery Option Standard  
 NOTE: Tool Shank Tolerance must be h6 or better, h4 for holders with ID smaller than 5mm

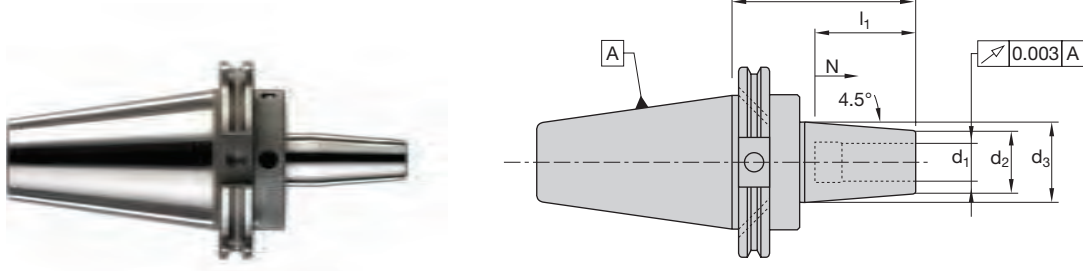

## CAT40 – Inch

SAP No.	Designation	Dimensions (inch)						
		d <sub>1</sub>	A	d <sub>2</sub>	d <sub>3</sub>	I <sub>1</sub>	N	g
<b>STANDARD PROJECTION</b>								
72.303.500.110	T0635-95/FCV40	0.250	3.74	0.83	1.06	1.42	0.39	M5
72.303.500.280	T0953-95/FCV40	0.375	3.74	0.95	1.26	1.65	0.39	M8x1
72.303.500.410	T1270-95/FCV40	0.500	3.74	1.06	1.34	1.85	0.39	M10x1
72.303.500.490	T1588-95/FCV40	0.625	3.74	1.06	1.34	1.97	0.39	M12x1
72.303.500.590	T1905-95/FCV40	0.750	3.74	1.30	1.65	2.05	0.39	M16x1
72.303.500.745	T2540-100/FCV40	1.000	3.94	1.73	2.09	2.44	0.39	M16x1

NOTE: All Holders Have 5/8-11 UNC Thread for Retention Knob & DIN FORM B Flange Coolant Delivery Option Standard

NOTE: Tool Shank Tolerance must be h6 or better, h4 for holders with ID smaller than 5mm

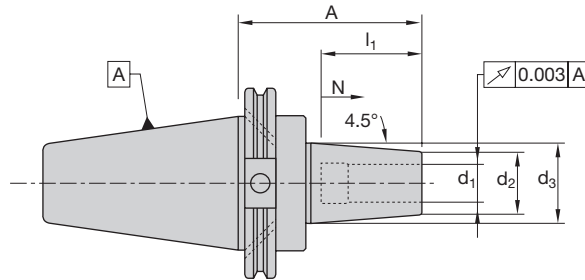

**CAT40 – Metric**

SAP No.	Designation	Dimensions (mm)						
		d <sub>1</sub>	A	d <sub>2</sub>	d <sub>3</sub>	l <sub>1</sub>	N	g
<b>STANDARD PROJECTION</b>								
9087273	T0300-95/CAT-40	3	95	15	20	20	5	M6
9087286	T0400-95/CAT-40	4	95	15	20	20	5	M6
9087287	T0500-95/CAT-40	5	95	15	20	25	5	M6
9074627	T0600-95/CAT-40	6	95	21	27	36	10	M5
9074628	T0800-95/CAT-40	8	95	21	27	36	10	M6
9074629	T1000-95/CAT-40	10	95	24	32	42	10	M8x1
9074630	T1200-95/CAT-40	12	95	24	32	47	10	M10x1
9074658	T1400-95/CAT-40	14	95	27	34	47	10	M10x1
9074631	T1600-95/CAT-40	16	95	27	34	50	10	M12x1
9074664	T1800-95/CAT-40	18	95	33	42	50	10	M12x1
9074632	T2000-95/CAT-40	20	95	33	42	52	10	M16x1
9074760	T2500-100/CAT-40	25	100	44	53	58	10	M16x1
9074672	T3200-100/CAT-40	32	100	44	53	62	10	M16x1
<b>LONG PROJECTION</b>								
9074650	T0600-120/CAT-40	6	120	21	27	36	10	M5
9074652	T0800-120/CAT-40	8	120	21	27	36	10	M6
9074654	T1000-120/CAT-40	10	120	24	32	42	10	M8x1
9074656	T1200-120/CAT-40	12	120	24	32	47	10	M10x1
9074659	T1400-120/CAT-40	14	120	27	34	47	10	M10x1
9074662	T1600-120/CAT-40	16	120	27	34	50	10	M12x1
9074665	T1800-120/CAT-40	18	120	33	42	50	10	M12x1
9074667	T2000-120/CAT-40	20	120	33	42	52	10	M16x1
9074669	T2500-120/CAT-40	25	120	44	53	58	10	M16x1
9074673	T3200-120/CAT-40	32	120	44	53	62	10	M16x1
<b>EXTRA LONG PROJECTION</b>								
9074651	T0600-160/CAT-40	6	160	21	32	36	10	M5
9074653	T0800-160/CAT-40	8	160	21	32	36	10	M6
9074655	T1000-160/CAT-40	10	160	24	34	42	10	M8x1
9074657	T1200-160/CAT-40	12	160	24	34	47	10	M10x1
9074661	T1400-160/CAT-40	14	160	27	42	47	10	M10x1
9074663	T1600-160/CAT-40	16	160	27	42	50	10	M12x1
9074666	T1800-160/CAT-40	18	160	33	44	50	10	M12x1
9074668	T2000-160/CAT-40	20	160	44	53	52	10	M16x1
9074671	T2500-160/CAT-40	25	160	44	53	58	10	M16x1
9074674	T3200-160/CAT-40	32	160	44	53	62	10	M16x1

NOTE: All Holders Have 5/8-11 UNC Thread for Retention Knob & DIN FORM B Flange Coolant Delivery Option Standard  
 NOTE: Tool Shank Tolerance must be h6 or better, h4 for holders with ID smaller than 5mm

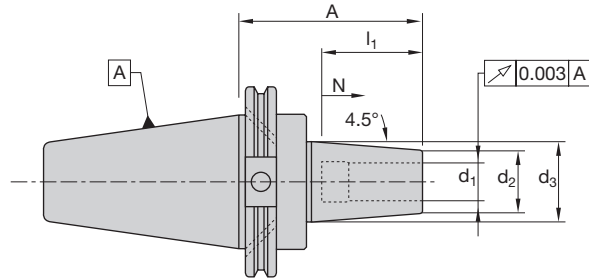

## CAT50 – Inch

SAP No.	Designation	Dimensions (inch)						
		d <sub>1</sub>	A	d <sub>2</sub>	d <sub>3</sub>	I <sub>1</sub>	N	g
<b>STANDARD PROJECTION</b>								
9074085	T0635-95/CAT-50	0.250	3.74	0.83	1.06	1.42	0.39	M5
9074102	T0953-95/CAT-50	0.375	3.74	0.95	1.26	1.65	0.39	M8x1
9074105	T1270-95/CAT-50	0.500	3.74	1.06	1.34	1.85	0.39	M10x1
9074108	T1588-95/CAT-50	0.625	3.74	1.06	1.34	1.97	0.39	M12x1
9074111	T1905-95/CAT-50	0.750	3.74	1.30	1.65	2.05	0.39	M16x1
9074115	T2540-105/CAT-50	1.000	4.13	1.73	2.09	2.44	0.39	M16x1
9074118	T3175-105/CAT-50	1.250	4.13	1.73	2.09	2.44	0.39	M16x1
<b>EXTRA LONG PROJECTION</b>								
9074101	T0635-160/CAT-50	0.250	6.30	0.83	1.26	1.42	0.39	M5
9074104	T0953-160/CAT-50	0.375	6.30	0.95	1.34	1.65	0.39	M8x1
9074107	T1270-160/CAT-50	0.500	6.30	1.06	1.65	1.85	0.39	M10x1
9074110	T1588-160/CAT-50	0.625	6.30	1.06	1.65	1.97	0.39	M12x1
9074113	T1905-160/CAT-50	0.750	6.30	1.30	2.01	2.05	0.39	M16x1
9074117	T2540-160/CAT-50	1.000	6.30	1.73	2.36	2.44	0.39	M16x1
9074120	T3175-160/CAT-50	1.250	6.30	1.73	2.36	2.44	0.39	M16x1

NOTE: All Holders Have 1-8 UNC Thread for Retention Knob & DIN FORM B Flange Coolant Delivery Option-Standard

NOTE: Tool Shank Tolerance must be h6 or better, h4 for holders with ID smaller than 5mm

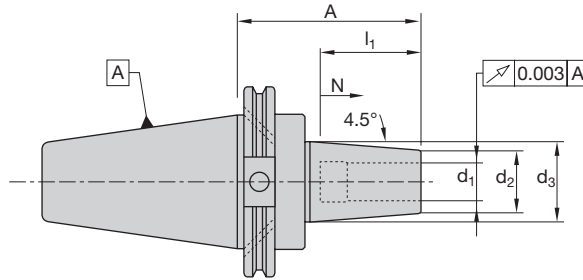

CAT50 – Metric								
SAP No.	Designation	Dimensions (mm)						
		$d_1$	A	$d_2$	$d_3$	$l_1$	N	g
<b>STANDARD PROJECTION</b>								
9074144	T0600-95/CAT-50	6	95	21	27	36	10	M5
9074147	T0800-95/CAT-50	8	95	21	27	36	10	M6
9074150	T1000-95/CAT-50	10	95	24	32	42	10	M8x1
9074153	T1200-95/CAT-50	12	95	24	32	47	10	M10x1
9074156	T1400-95/CAT-50	14	95	27	34	47	10	M10x1
9074160	T1600-95/CAT-50	16	95	27	34	50	10	M12x1
9074163	T1800-95/CAT-50	18	95	33	42	50	10	M12x1
9074166	T2000-95/CAT-50	20	95	33	42	52	10	M16x1
9074170	T2500-105/CAT-50	25	105	44	53	58	10	M16x1
9074173	T3200-105/CAT-50	32	105	44	53	62	10	M16x1
<b>EXTRA LONG PROJECTION</b>								
9074146	T0600-160/CAT-50	6	160	21	32	36	10	M5
9074149	T0800-160/CAT-50	8	160	21	32	36	10	M6
9074152	T1000-160/CAT-50	10	160	24	34	42	10	M8x1
9074155	T1200-160/CAT-50	12	160	24	34	47	10	M10x1
9074159	T1400-160/CAT-50	14	160	27	42	47	10	M10x1
9074162	T1600-160/CAT-50	16	160	27	42	50	10	M12x1
9074165	T1800-160/CAT-50	18	160	33	51	50	10	M12x1
9074168	T2000-160/CAT-50	20	160	33	51	52	10	M16x1
9074172	T2500-160/CAT-50	25	160	44	60	58	10	M16x1
9074175	T3200-160/CAT-50	32	160	44	60	62	10	M16x1

NOTE: All Holders Have 1-8 UNC Thread for Retention Knob & DIN FORM B Flange Coolant Delivery Option-Standard  
 NOTE: Tool Shank Tolerance must be h6 or better, h4 for holders with ID smaller than 5mm

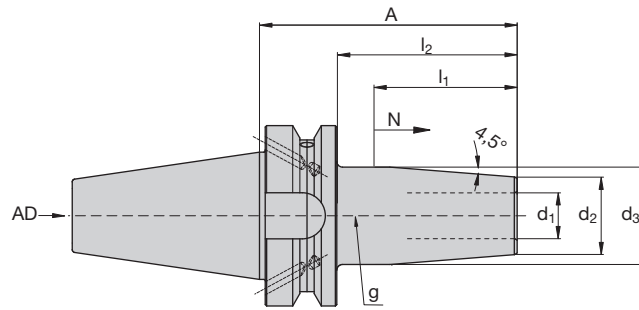

## BT30 – Metric

SAP No.	Designation	Dimensions (mm)							
		$d_1$	A	$l_2$	$d_2$	$d_3$	$l_1$	N	g
<b>STANDARD PROJECTION</b>									
5020062	T0300-80/BT30	3	80	58	15	25	20	5	M6
5020063	T0400-80/BT30	4	80	58	15	25	20	5	M6
5020064	T0500-80/BT30	5	80	58	15	25	25	5	M6
5020065	T0600-80/BT30	6	80	58	21	31	36	10	M5
5020066	T0800-80/BT30	8	80	58	21	31	36	10	M6
5020067	T1000-80/BT30	10	80	58	24	34	42	10	M8x1
5020068	T1200-80/BT30	12	80	58	24	34	47	10	M10x1
5020069	T1600-80/BT30	16	80	58	27	37	50	10	M12x1
5020070	T2000-80/BT30	20	80	58	33	43	52	10	M16x1

Note: All holders have a 12mm x 1 thread for retention knob

Note: All holders have DIN Form "B" coolant delivery option as a standard feature.

Note: Cutting tool shank tolerance must be h6 or better, h4 for all holders with ID bores smaller than 5mm.



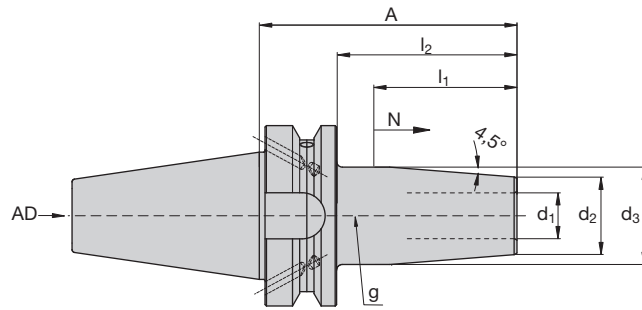

BT40 – Metric									
SAP No.	Designation	Dimensions (mm)							
		$d_1$	A	$l_2$	$d_2$	$d_3$	$l_1$	N	g
<b>STANDARD PROJECTION</b>									
6726807	T0300/BT40	3	90	63	15	20	20	5	M6
6726621	T0400/BT40	4	90	63	15	20	20	5	M6
6726622	T0500/BT40	5	90	63	15	20	25	5	M6
6726499	T0600/BT40	6	90	63	21	27	36	10	M5
6726484	T0800/BT40	8	90	63	21	27	36	10	M6
6726485	T1000/BT40	10	90	63	24	32	42	10	M8x1
6726486	T1200/BT40	12	90	63	24	32	47	10	M10x1
6726500	T1400/BT40	14	90	63	27	34	47	10	M10x1
6726470	T1600/BT40	16	90	63	27	34	50	10	M12x1
6726501	T1800/BT40	18	90	63	33	42	50	10	M12x1
6726469	T2000/BT40	20	90	63	33	42	52	10	M16x1
6726502	T2500/BT40	25	100	73	44	53	58	10	M16x1
9117365	T3200/BT40	32	100	73	44	53	62	10	M16x1
<b>LONG PROJECTION</b>									
6727101	T0600-120/BT40	6	120	94	21	27	36	10	M5
6727102	T0800-120/BT40	8	120	94	21	27	36	10	M6
6727103	T1000-120/BT40	10	120	94	24	32	42	10	M8x1
6727104	T1200-120/BT40	12	120	94	24	32	47	10	M10x1
6727105	T1400-120/BT40	14	120	94	27	34	47	10	M10x1
6727106	T1600-120/BT40	16	120	94	27	34	50	10	M12x1
6727107	T1800-120/BT40	18	120	94	33	42	50	10	M12x1
6727108	T2000-120/BT40	20	120	94	33	42	52	10	M16x1
6727109	T2500-120/BT40	25	120	94	44	52	58	10	M16x1
9126834	T3200-120/BT40	32	120	94	44	52	62	10	M16x1
<b>EXTRA LONG PROJECTION</b>									
6726811	T0600-160/BT40	6	160	134	21	32	36	10	M5
6726812	T0800-160/BT40	8	160	134	21	32	36	10	M6
6726813	T1000-160/BT40	10	160	134	24	34	42	10	M8x1
6726814	T1200-160/BT40	12	160	134	24	34	47	10	M10x1
6726815	T1400-160/BT40	14	160	134	27	42	47	10	M10x1
6726816	T1600-160/BT40	16	160	134	27	42	50	10	M12x1
6726817	T1800-160/BT40	18	160	134	33	51	50	10	M12x1
6726818	T2000-160/BT40	20	160	134	33	51	52	10	M16x1
6726819	T3200-160/BT40	25	160	134	44	52.5	62	10	M16x1

## Polygon Shank "CAPTO" Compatible | ThermoGrip® Standard

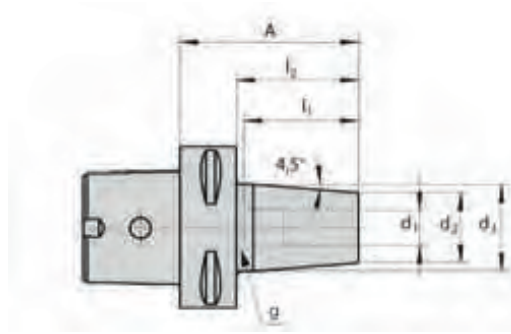
25 000  
U/min  
R.P.M.

## Polygon Shank "CAPTO" Compatible – C6 – Inch

SAP No.	Designation	Dimensions (inch)							
		d <sub>1</sub>	A	l <sub>2</sub>	d <sub>2</sub>	d <sub>3</sub>	l <sub>1</sub>	N	g
5054341	T0635-80/C6	0.250	3.15	2.28	0.83	1.06	1.42	0.39	M5
5054343	T0953-80/C6	0.375	3.15	2.28	0.94	1.26	1.65	0.39	M8x1
5054344	T1270-85/C6	0.500	3.35	2.48	1.06	1.34	1.85	0.39	M10x1
5054345	T1588-85/C6	0.625	3.35	2.48	1.06	1.34	1.97	0.39	M12x1
5054347	T1905-85/C6	0.750	3.35	2.48	1.30	1.65	2.05	0.39	M16x1
5054348	T2540-95/C6	1.000	3.74	2.87	1.73	2.09	2.44	0.39	M16x1
5054349	T3175-95/C6	1.250	3.74	2.87	1.73	2.09	2.44	0.39	M16x1

For carbide and HSS tools

All clamping chucks are suitable for central coolant

Delivery including backup screw

Shank tolerance 3; 4 = h 4 / 5 = h 5 / 6 = h 6

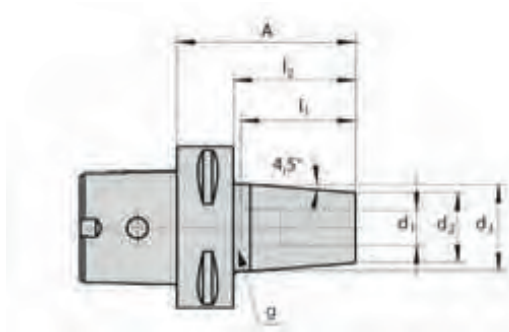

**Polygon Shank “CAPTO” Compatible – C6 – Metric**

SAP No.	Designation	Dimensions (inch)							
		d <sub>1</sub>	A	l <sub>2</sub>	d <sub>2</sub>	d <sub>3</sub>	l <sub>1</sub>	N	g
6727324	T0600-80/C6	6	80	58	21	27	36	10	M5
6727325	T0800-80/C6	8	80	58	21	27	36	10	M6
6727326	T1000-80/C6	10	80	58	24	32	42	10	M8x1
6727327	T1200-80/C6	12	80	58	24	32	47	10	M10x1
6727328	T1400-85/C6	14	85	63	27	34	47	10	M10x1
6727329	T1600-85/C6	16	85	63	27	34	50	10	M12x1
6727330	T1800-85/C6	18	85	63	33	42	50	10	M12x1
6727331	T2000-85/C6	20	85	63	33	42	52	10	M16x1
6727332	T2500-90/C6	25	90	68	44	53	58	10	M16x1
6727333	T3200-95/C6	32	95	73	44	53	62	10	M16x1

# SLIM DESIGN THERMOGRIP® HOLDERS

## DESIGNED FOR DEEP CAVITIES AND DIFFICULT CONTOURS

Slim Design Tool Holders utilize our ThermoGrip® technology and were developed specifically for the die and mold industry. Today but they also fit aerospace and medical applications as well. Like all BILZ tools, they maintain precision and productivity—even at extended lengths over a full range of sizes.

- Perfect for Die & Mold, Aerospace Industries
- Line includes extensions to 10" long
- The most complete product range available



VIEW  
THE  
WEBSITE

## TSF THERMOGRIP® SLIMLINE

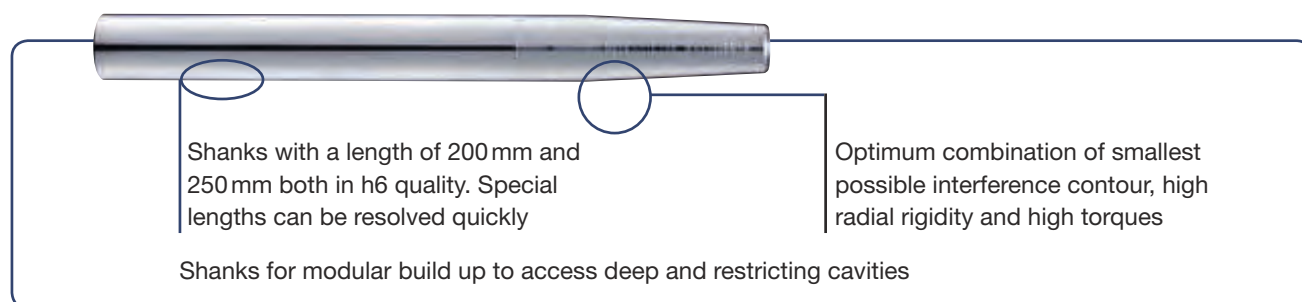
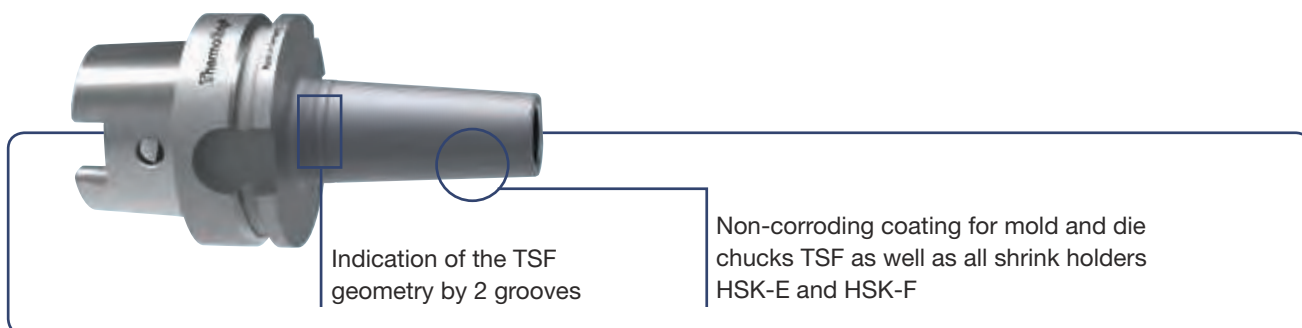
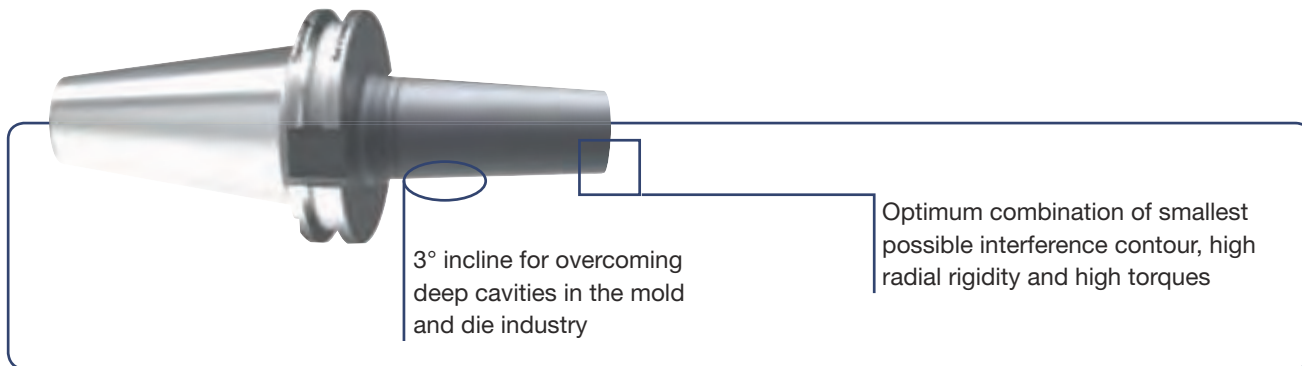

Introducing the new shrink chuck TSF ThermoGrip®—the slim version is specially developed for the mold and die industry. This chuck type is used for induction shrinking of carbide tools with shank tolerance h6. Due to the slim shape of this new chuck, interfering edges are a thing of the past.

The outside geometry of the new shrink chuck TSF is designed **with a 3° slope**, compatible to dies and molds. The chucks have a **concentricity < 0.003 mm and are fine balanced at < 1 gmm/kg**. Specifically for these slim chucks all new ThermoGrip® shrinking units are programmed with the parameters of heating time and generator output for the shrinking of all possible shank diameters. The previous shrinking units can be upgraded with these parameters. As a result, these thin-walled chucks can be shrunk with the highest reliability and without the risk of overheating.

Due to the broad product range, chucks with different lengths are available **for all applications on all standard spindles**.

## HSK-E32 | ThermoGrip® SlimLine

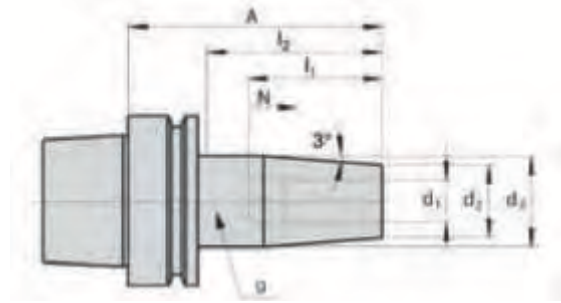

## HSK-E32 SlimLine – Inch

SAP No.	Designation	Dimensions (inch)							
		$d_1$	A	$l_2$	$d_2$	$d_3$	$l_1$	N	g
<b>LONG PROJECTION</b>									
5057309	TSF0318-94/HSK-E32	0.125	3.70	2.76	0.39	0.67	0.79	0.20	M6
5057315	TSF0635-104/HSK-E32	0.250	4.09	3.15	0.47	0.79	1.42	0.20	M5

Only for HM and solid carbide tools  
 All clamping chucks are suitable for central coolant  
 Delivery including backup screw  
 Shank tolerance 3; 4 = h 4 / 5 = h 5 / 6 = h 6

## HSK-E32 SlimLine – Metric

SAP No.	Designation	Dimensions (mm)							
		$d_1$	A	$l_2$	$d_2$	$d_3$	$l_1$	N	g
<b>STANDARD PROJECTION</b>									
9078742	TSF0300-40/HSK-E32	3	64	40	9	13	20	5	M6
9078744	TSF0400-40/HSK-E32	4	64	40	10	14	20	5	M6
9078746	TSF0600-50/HSK-E32	6	74	50	12	17	36	5	M5
9078748	TSF0800-50/HSK-E32	8	74	50	12	17	36	5	M6
9078750	TSF1000-55/HSK-E32	10	78	55	16	21	42	5	M8x1
<b>LONG PROJECTION</b>									
9078743	TSF0300-70/HSK-E32	3	94	70	9	16	20	5	M6
9078745	TSF0400-70/HSK-E32	4	94	70	10	17	20	5	M6
9078747	TSF0600-80/HSK-E32	6	104	80	12	20	36	5	M5
9078749	TSF0800-80/HSK-E32	8	104	80	12	20	36	5	M6
9079751	TSF1000-80/HSK-E32	10	104	80	16	22	42	5	M8x1

Only for HM and solid carbide tools  
 All clamping chucks are suitable for central coolant  
 Delivery including backup screw  
 Shank tolerance 3; 4 = h 4 / 5 = h 5 / 6 = h 6

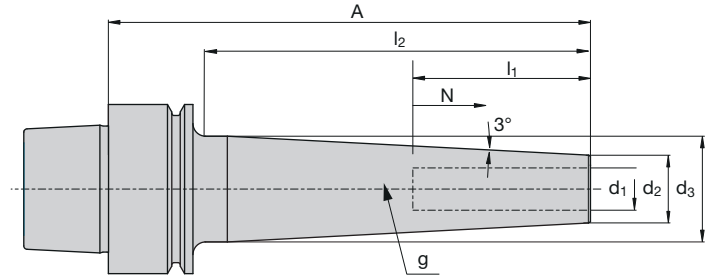

HSK-E50 SlimLine – Metric									
SAP No.	Designation	Dimensions (mm)							
		d <sub>1</sub>	A	l <sub>2</sub>	d <sub>2</sub>	d <sub>3</sub>	l <sub>1</sub>	N	g
<b>SHORT PROJECTION</b>									
9078910	TSF0600-60/HSK-E40	6	60	38	12	16	36	5	M5
9078925	TSF0800-60/HSK-E40	8	60	38	14	18	36	5	M6
9078926	TSF1000-60/HSK-E40	10	60	38	16	20	42	5	M8x1
9078927	TSF1200-60/HSK-E40	12	60	38	18	22	47	5	M10x1
<b>STANDARD PROJECTION</b>									
9078566	TSF0300-64/HSK-E40	3	64	40	11	13	20	5	M6
9078570	TSF0400-64/HSK-E40	4	64	40	11	14	20	5	M6
9078572	TSF0600-84/HSK-E40	6	84	60	12	18	36	5	M5
9078576	TSF0800-84/HSK-E40	8	84	60	14	20	36	5	M6
9078579	TSF1000-84/HSK-E40	10	84	60	16	22	42	5	M8x1
9078582	TSF1200-84/HSK-E40	12	84	60	18	24	47	5	M10x1
<b>LONG PROJECTION</b>									
9078569	TSF0300-94/HSK-E40	3	94	70	11	16	20	5	M6
9078571	TSF0400-94/HSK-E40	4	94	70	11	17	20	5	M6
9078573	TSF0600-114/HSK-E40	6	114	90	12	21	36	5	M5
9078577	TSF0800-114/HSK-E40	8	114	90	14	23	36	5	M6
9078580	TSF1000-114/HSK-E40	10	114	90	16	25	42	5	M8x1
9078583	TSF1200-114/HSK-E40	12	114	90	18	27	47	5	M10x1
<b>EXTRALONG PROJECTION</b>									
9078574	TSF0600-144/HSK-E40	6	144	120	12	24	36	5	M5
9078578	TSF0800-144/HSK-E40	8	144	120	14	26	36	5	M6
9078581	TSF1000-144/HSK-E40	10	144	120	16	28	42	5	M8x1
9078584	TSF1200-144/HSK-E40	12	144	120	18	30	47	5	M10x1

Only for HM and solid carbide tools  
 All clamping chucks are suitable for central coolant  
 Delivery including backup screw  
 Shank tolerance 3; 4 = h 4 / 5 = h 5 / 6 = h 6

## HSK-A63 | ThermoGrip® SlimLine

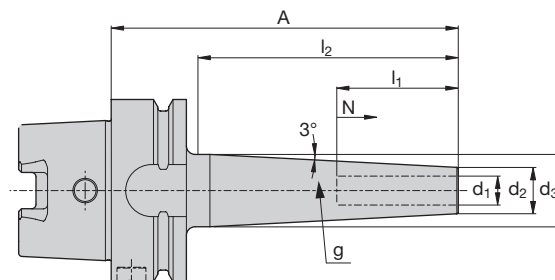

## HSK-A63 SlimLine – Metric

SAP No.	Designation	Dimensions (mm)							
		d <sub>1</sub>	NL	A	d <sub>2</sub>	d <sub>3</sub>	l <sub>1</sub>	N	g
<b>STANDARD PROJECTION</b>									
9078617	TSF0300-70/HSK-A63	3	40	70	11	13	20	5	M6
9078654	TSF0400-70/HSK-A63	4	40	70	11	14	20	5	M6
9078658	TSF0600-90/HSK-A63	6	60	90	12	18	36	5	M5
9078670	TSF0800-90/HSK-A63	8	60	90	14	20	36	5	M6
9078676	TSF1000-90/HSK-A63	10	60	90	16	22	42	5	M8x1
9078725	TSF1200-90/HSK-A63	12	60	90	18	24	47	5	M10x1
9078728	TSF1600-90/HSK-A63	16	60	90	22	28	50	5	M12x1
<b>LONG PROJECTION</b>									
9078652	TSF0300-100/HSK-A63	3	70	100	11	16	20	5	M6
9078655	TSF0400-100/HSK-A63	4	70	100	11	17	20	5	M6
9078660	TSF0600-120/HSK-A63	6	90	120	12	21	36	5	M5
9078673	TSF0800-120/HSK-A63	8	90	120	14	23	36	5	M6
9078677	TSF1000-120/HSK-A63	10	90	120	16	25	42	5	M8x1
9078726	TSF1200-120/HSK-A63	12	90	120	18	27	47	5	M10x1
9078729	TSF1600-120/HSK-A63	16	90	120	22	31	50	5	M12x1
<b>EXTRA LONG PROJECTION</b>									
9078653	TSF0300-130/HSK-A63	3	100	130	11	19	20	5	M6
9078657	TSF0400-130/HSK-A63	4	100	130	11	20	20	5	M6
9078661	TSF0600-150/HSK-A63	6	120	150	12	24	36	5	M5
9078674	TSF0800-150/HSK-A63	8	120	150	14	26	36	5	M6
9078678	TSF1000-150/HSK-A63	10	120	150	16	28	42	5	M8x1
9078624	TSF1200-150/HSK-A63	12	120	150	18	30	47	5	M10x1
9078730	TSF1600-150/HSK-A63	16	120	150	22	34	50	5	M12x1

Only for HMan and solid carbide tools

All clamping chucks are suitable for central coolant

Please Order Coolant Tube Catalog No. HSK63-18 separately

Delivery including backup screw

Shank tolerance 3; 4 = h 4 / 5 = h 5 / 6 = h 6

Including data carrier bore



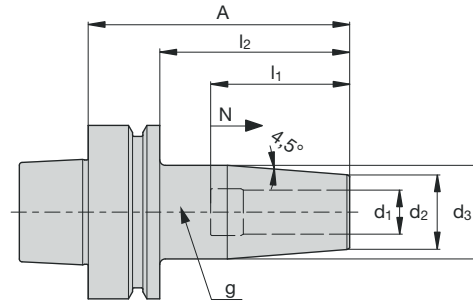

HSK-F63 SlimLine – Inch									
SAP No.	Designation	Dimensions (inch)							
		d <sub>1</sub>	A	l <sub>2</sub>	d <sub>2</sub>	d <sub>3</sub>	l <sub>1</sub>	N	g
<b>STANDARD PROJECTION</b>									
5057252	TSF0318-70/HSK-F63	0.125	2.76	1.57	0.39	0.55	0.79	0.20	M6
5057147	TSF0476-90/HSK-F63	0.187	3.54	2.36	0.43	0.71	0.98	0.20	M6
5057162	TSF0635-90/HSK-F63	0.250	3.54	2.36	0.47	0.71	1.42	0.20	M5
5057165	TSF0953-90/HSK-F63	0.375	3.54	2.36	0.63	0.87	1.65	0.20	M8X1
5057167	TSF1270-90/HSK-F63	0.500	3.54	2.36	0.79	1.02	1.85	0.20	M10X1
5053815	TSF1588-90/HSK-F63	0.625	3.54	2.36	0.87	1.10	1.97	0.20	M12X1

All holders can be run with internal coolant

NOTE: Tool Shank Tolerance must be h6 or better, h4 for holders with ID smaller than 5mm

## TSFV Shrink Extensions | ThermoGrip® SlimLine

BILZ

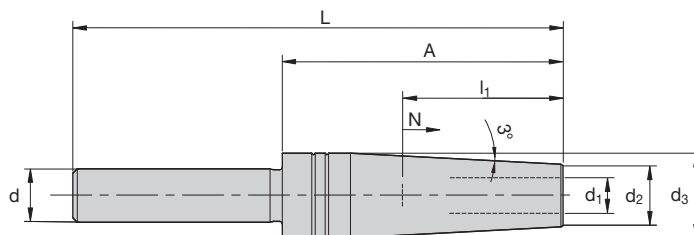

## TSFV SlimLine – Inch

SAP No.	Designation	Dimensions (inch)								
		$d_1$	A	D	L	$l_1$	$d_2$	$d_3$	N	g
<b>STANDARD PROJECTION</b>										
5051691	TSFV0318-110/1270	0.125	2.48	0.50	4.33	20	0.39	0.50	0.20	M6
5051697	TSFV0318-110/1905	0.125	2.28	0.75	4.33	20	0.39	0.75	0.20	M6
5051695	TSFV0476-110/1270	0.187	2.48	0.50	4.33	25	0.43	0.50	0.20	M6
5051698	TSFV0476-110/1905	0.187	2.28	0.75	4.33	25	0.43	0.75	0.20	M6
5051696	TSFV0635-110/1270	0.250	2.48	0.50	4.33	36	0.47	0.50	0.39	M6
5051699	TSFV0635-110/1905	0.250	2.28	0.75	4.33	36	0.47	0.75	0.39	M6
5051700	TSFV0953-110/1905	0.375	2.28	0.75	4.33	42	0.63	0.75	0.39	M8x1
<b>EXTRA LONG PROJECTION</b>										
5051735	TSFV0318-250/1905	0.125	7.79	0.75	9.84	20	0.39	0.75	0.20	M6
5051736	TSFV0476-250/1905	0.187	7.79	0.75	9.84	25	0.43	0.75	0.20	M6
5051737	TSFV0635-250/1905	0.250	7.79	0.75	9.84	36	0.47	0.75	0.39	M6
5051738	TSFV0953-250/1905	0.375	7.79	0.75	9.84	42	0.63	0.75	0.39	M8x1
5051740	TSFV1270-250/2540	0.500	7.59	1.00	9.84	47	0.79	1.00	0.39	M10x1
5051500	TSFV1588-250/2540	0.625	7.59	1.00	9.84	50	0.87	1.00	0.39	M10x1

All holders can be run with internal coolant

NOTE: Tool Shank Tolerance must be h6 or better, h4 for holders with ID smaller than 5mm

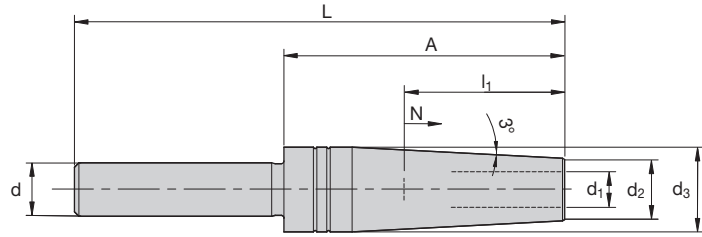

TSFV SlimLine – Metric										
SAP No.	Designation	Dimensions (mm)								
		d <sub>1</sub>	A	D	L	l <sub>1</sub>	d <sub>2</sub>	d <sub>3</sub>	N	g
<b>STANDARD PROJECTION</b>										
9195953	TSFV0300-110/12	3	63	12	110	20	9	11.8	5	M6
9196066	TSFV0300-110/16	3	60	16	110	20	9	13	5	M6
9196082	TSFV0300-110/20	3	58	20	110	20	9	13	5	M6
9195985	TSFV0400-110/12	4	63	12	110	20	10	11.8	5	M6
9196068	TSFV0400-110/16	4	60	16	110	20	10	14	5	M6
9196083	TSFV0400-110/20	4	58	20	110	20	10	14	5	M6
9195986	TSFV0500-110/12	5	63	12	110	25	11	11.8	5	M6
9196069	TSFV0500-110/16	5	58	16	110	25	11	15	5	M6
9196084	TSFV0500-110/20	5	58	20	110	25	11	15	5	M6
9196015	TSFV0600-110/12	6	63	12	110	36	12	17	10	M5
9196070	TSFV0600-110/16	6	60	16	110	36	12	15.8	10	M5
9196085	TSFV0600-110/20	6	58	20	110	36	12	16	10	M5
9196016	TSFV0800-110/12	8	63	12	110	36	14	19	10	M6
9196081	TSFV0800-110/16	8	60	16	110	36	14	19	10	M6
9196086	TSFV0800-110/20	8	58	20	110	36	14	19	10	M6
9196088	TSFV1000-110/20	10	58	20	110	42	16	19.8	10	M8x1
9196112	TSFV1200-110/20	12	58	20	110	47	18	19.8	10	M10x1
<b>EXTRA LONG PROJECTION</b>										
9196118	TSFV0300-200/16	3	150	16	200	20	9	16	5	M6
9196130	TSFV0400-200/16	4	150	16	200	20	10	16	5	M6
9196134	TSFV0500-200/16	5	150	16	200	25	11	16	5	M6
9196138	TSFV0600-200/16	6	150	16	200	36	12	16	10	M5
9196139	TSFV0600-250/20	6	198	20	250	36	12	20	10	M5
9196141	TSFV0800-250/20	8	198	20	250	36	14	20	10	M6
9196142	TSFV1000-250/20	10	198	20	250	42	16	20	10	M8x1
9196144	TSFV1200-250/25	12	193	25	250	47	18	25	10	M10x1
9196147	TSFV1600-250/25	16	193	25	250	50	22	25	10	M12x1

All holders can be run with internal coolant

NOTE: Tool Shank Tolerance must be h6 or better, h4 for holders with ID smaller than 5mm

# VIDAT THERMOGRIP® HOLDERS

## ThermoGrip® VIDAT: Vibrations DAmpling Technology from BILZ

Vibrations caused during the first extension deflection are effectively absorbed by integrated dampers. VIDAT extensions achieve damping rates of at least 4dB in comparison to normal extensions. The very rigid nature of the shrinking process means that long, slim extensions in particular have a tendency to chatter and vibrate. VIDAT extensions reduce this effect, thus considerably increasing the area of application.

- reduce the vibrations in the clamping system
- improve the surface quality of the workpiece
- increase tool life

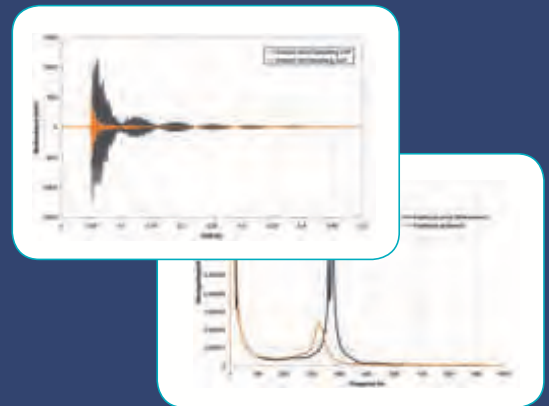

VIEW  
THE  
WEBSITE



VIDAT – Inch									
Ident No.	Designation	Dimensions (inch)							
		D <sub>1</sub>	A	D	L	D	D <sub>3</sub>	L <sub>1</sub>	N
	TLNE0318-210/1905	0,125	6,220	0,750	8,27	0,125	0,780	1,417	0,197
	TLNE0476-210/1905	0,187	6,220	0,750	8,27	0,187	0,780	1,417	0,197
	TLNE0635-210/1905	0,250	6,220	0,750	8,27	0,250	0,780	1,654	0,197
	TLNE0953-210/1905	0,375	6,220	0,750	8,27	0,375	0,780	1,850	0,197
	TLNE1270-210/1905	0,500	9,528	0,750	8,27	0,500	0,976	1,654	0,197
	TLNE0635-300/2540	0,250	9,528	1,000	11,80	0,250	0,976	1,850	0,197
	TLNE0953-300/2540	0,375	9,528	1,000	11,80	0,375	0,976	1,850	0,197
	TLNE1270-300/2540	0,500	9,528	1,000	11,80	0,500	0,976	1,969	0,197
	TLNE1588-300/2540	0,625	9,370	1,000	11,80	0,625	1,252	1,850	0,197
	TLNE0953-300/3175	0,375	9,370	1,250	11,80	0,375	1,252	1,850	0,197
	TLNE1270-300/3175	0,500	9,370	1,250	11,80	0,500	1,252	1,969	0,197
	TLNE1588-300/3175	0,625	9,370	1,250	11,80	0,625	1,252	1,969	0,197
	TLNE1905-300/3175	0,750	9,370	1,250	11,80	0,750	1,252	2,047	0,197

Internal coolant supply up to max. 80 bar

VIDAT – Metric									
Ident No.	Designation	Dimensions (mm)							
		D <sub>1</sub>	A	D	L	D	D <sub>3</sub>	L <sub>1</sub>	N
5076576	TLNE0600-210/20	6	158	20	210	12	19,8	36	5
5072753	TLNE0800-210/20	8	158	20	210	14	19,8	36	5
5076578	TLNE1000-210/20	10	158	20	210	16	19,8	42	5
5076580	TLNE1200-210/20	12	158	20	210	18	19,8	47	5
5076582	TLNE1000-300/25	10	242	25	300	16	24,8	42	5
5072754	TLNE1200-300/25	12	242	25	300	18	24,8	47	5
5076584	TLNE1400-300/25	14	242	25	300	20	24,8	47	5
5076586	TLNE1600-300/25	16	242	25	300	22	24,8	50	5
5076587	TLNE1200-300/32	12	238	32	300	18	31,8	47	5
5076589	TLNE1400-300/32	14	238	32	300	20	31,8	47	5
5072755	TLNE1600-300/32	16	238	32	300	22	31,8	50	5
5076590	TLNE1800-300/32	18	238	32	300	25	31,8	50	5
5076591	TLNE2000-300/32	20	238	32	300	27	31,8	52	5

Internal coolant supply up to max. 80 bar

# HEAVY DUTY THERMOGRIP® HOLDERS

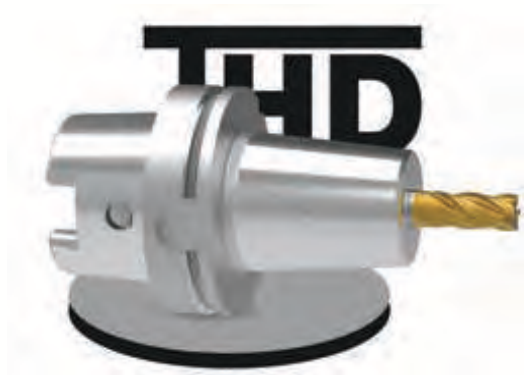

VIEW  
THE  
WEBSITE

**THD THERMOGRIP® HEAVY DUTY**

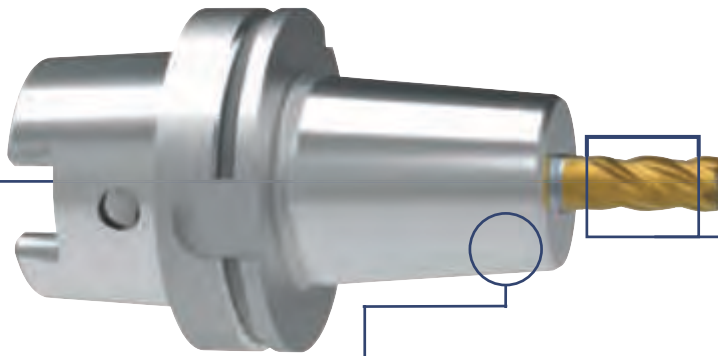

Due to the short and rigid design highest retention forces and torque transmission are guaranteed permanently.

High radial rigidity for best form stability at highest Metal removal rate.

Up to 50% more overlap – Suited for \*HPC cutting  
\* High Performance Cutting

**THD VS T STYLE**

- Standard “THD” style – Thicker wall for increased gripping strength.
- Greater ID bore tolerance overlap for increase gripping strength
- Reduced or elimination of cutting tool slippage or “pullout” for high cutting forces

- Standard “T” style - DIN standard wall thickness for everyday applications
- Smaller nose diameter for closer part clearances and smaller cavities
- Excellent cutting tool gripping strength for all “normal/everyday applications”

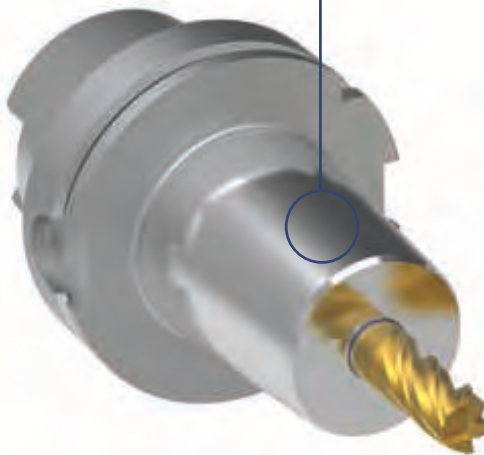

## THD CAT40 | ThermoGrip® Heavy Duty

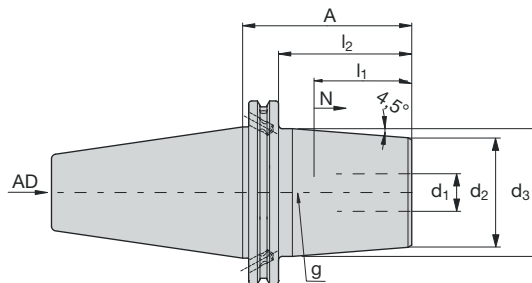

## THD CAT40 Heavy Duty – Inch

SAP No.	Designation	Dimensions (inch)							
		$d_1$	A	$l_2$	$d_2$	$d_3$	$l_1$	N	g
<b>STANDARD PROJECTION</b>									
5057676	THD1588-110/CAT40	0.625	4.33	3.58	1.97	2.36	1.97	0.39	M12x1
5057677	THD1905-110/CAT40	0.750	4.33	3.58	2.28	2.68	2.05	0.39	M16x1

All holders can be run with internal coolant

NOTE: Tool Shank Tolerance must be h6 or better, h4 for holders with ID smaller than 5mm

## THD HSK-A100 | ThermoGrip® Heavy Duty

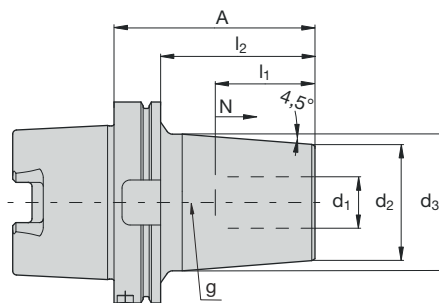

## THD HSK-A100 Heavy Duty – Inch

SAP No.	Designation	Dimensions (inch)							
		$d_1$	A	$l_2$	$d_2$	$d_3$	$l_1$	N	g
<b>STANDARD PROJECTION</b>									
5054390	THD1588-105/HSK-A100	0.625	4.13	2.99	1.97	2.36	1.97	0.39	M12x1
5054391	THD1905-110/HSK-A100	0.750	4.33	3.19	2.28	2.68	2.05	0.39	M16x1
5054392	THD2540-110/HSK-A100	1.000	4.33	3.19	2.52	2.99	2.44	0.39	M16x1
5054393	THD3175-120/HSK-A100	1.250	4.72	3.58	2.83	3.35	2.44	0.39	M16x1

All holders can be run with internal coolant

Please Order Coolant Tube Catalog No. HSK100-18 separately

NOTE: Tool Shank Tolerance must be h6 or better, h4 for holders with ID smaller than 5mm

## THD HSK-A100 Heavy Duty – Metric

SAP No.	Designation	Dimensions (mm)							
		$d_1$	A	$l_2$	$d_2$	$d_3$	$l_1$	N	g
<b>STANDARD PROJECTION</b>									
5029007	THD1600-105/HSK-A100	16	105	76	50	61	50	10	M12x1
5025872	THD2000-110/HSK-A100	20	110	81	58	70	52	10	M16x1
5026038	THD2500-110/HSK-A100	25	110	81	64	76	58	10	M16x1
5028982	THD3200-120/HSK-A100	32	120	91	72	85	62	10	M16x1

All holders can be run with internal coolant

Please Order Coolant Tube Catalog No. HSK100-18 separately

NOTE: Tool Shank Tolerance must be h6 or better, h4 for holders with ID smaller than 5mm



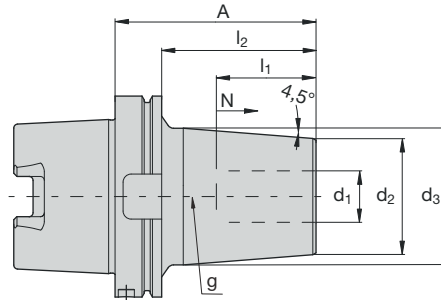

**THD HSK-A125 Heavy Duty – Inch**

SAP No.	Designation	Dimensions (inch)							
		$d_1$	A	$l_2$	$d_2$	$d_3$	$l_1$	N	g
<b>STANDARD PROJECTION</b>									
5054394	THD1588-110/HSK-A125	0.625	4.33	3.19	1.97	2.36	1.97	0.39	M12x1
5054395	THD1905-115/HSK-A125	0.750	4.53	3.39	2.28	2.68	2.05	0.39	M16x1
5054396	THD2540-120/HSK-A125	1.000	4.72	3.58	2.52	2.99	2.44	0.39	M16x1
5054397	THD3175-125/HSK-A125	1.250	4.92	3.78	2.83	3.35	2.44	0.39	M16x1

All holders can be run with internal coolant  
 Please Order Coolant Tube Catalog No. HSK125-18 separately  
 NOTE: Tool Shank Tolerance must be h6 or better, h4 for holders with ID smaller than 5mm

**THD HSK-A125 Heavy Duty – Metric**

SAP No.	Designation	Dimensions (mm)							
		$d_1$	A	$l_2$	$d_2$	$d_3$	$l_1$	N	g
<b>STANDARD PROJECTION</b>									
5029874	THD1600-110/HSK-A125	16	110	81	50	60	50	10	M12x1
5031102	THD2000-115/HSK-A125	20	115	86	58	68	52	10	M16x1
5029870	THD2500-120/HSK-A125	25	120	91	64	76	58	10	M16x1
5031105	THD3200-125/HSK-A125	32	125	96	72	72	62	10	M16x1

All holders can be run with internal coolant  
 Please Order Coolant Tube Catalog No. HSK125-18 separately  
 NOTE: Tool Shank Tolerance must be h6 or better, h4 for holders with ID smaller than 5mm

# COLLETS TO DIN 6499

## A PERFECT FIT

With the development of the patented TER shrink collet, we have been able to revolutionise the use of collets and collet chucks in the production process.

### USING TER MEANS PROFITING FROM THE ADVANTAGES OF COLLET SHRINKING:

- Run-out < 3 µm at 3 x D (diameter)
- Maximum holding forces
- Rigidity
- Low-wear monoblock properties without the need to replace existing collet chucks or spindles.

The short and extremely stable tool clamping with TER achieves a run-out of < 3µm. Tool life is considerably improved due to the precise guidance of the tool and ultra-precise change accuracy.

Your length adjustment is maintained even after many cycles—with optimum results.

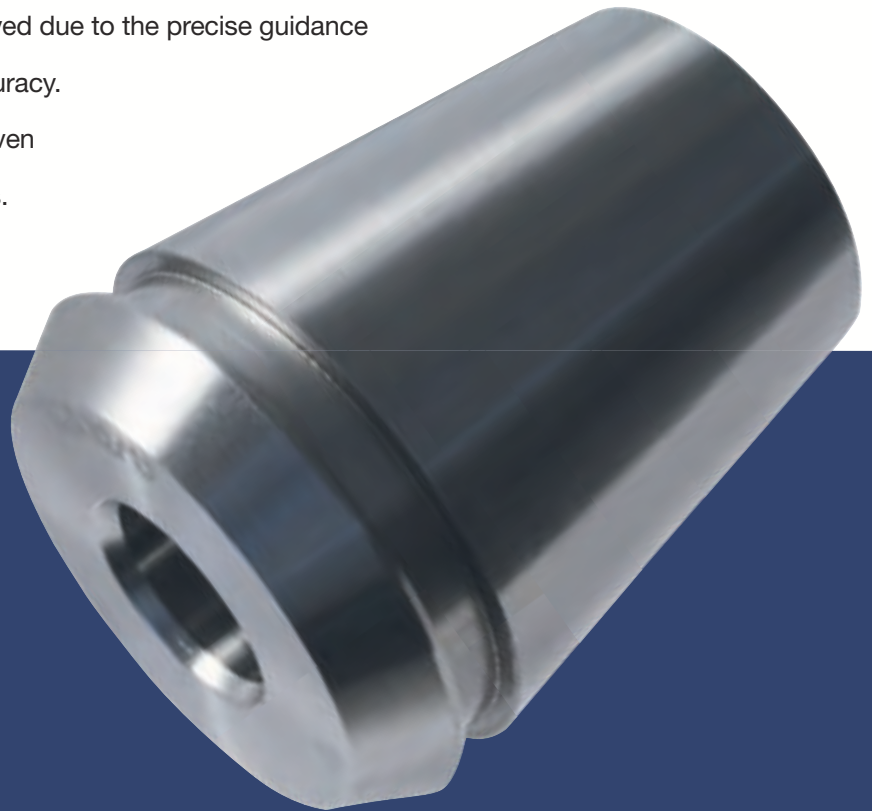

VIEW  
THE  
WEBSITE

**Using high efficiency to reduce production costs – TER to DIN 6499 makes it possible!**

Increase productivity in a short period of time	High quality machining for top results
<b>High-speed machining</b> <ul style="list-style-type: none"> <li>• High transmittable torque</li> <li>• Stable clamping</li> <li>• Maximum holding forces</li> <li>• Ultra-precise, quick tool changes (&lt; 30s)</li> </ul>	<b>High precision and process-secure</b> <ul style="list-style-type: none"> <li>• Excellent run-out properties (&lt; 3 µm)</li> <li>• High repeatability due to precise clamping</li> </ul>
Machine longer due to less wear	Improve manufacturing without changing production processes
<b>Increase of tool life for cutting tools up to 300%</b> <ul style="list-style-type: none"> <li>• High stability of the system</li> <li>• Minimum load from axial forces</li> <li>• Precise clamping means less damage</li> <li>• Resistant to dirt (sealed monoblock system)</li> </ul>	<b>No need to retool . . .</b> <ul style="list-style-type: none"> <li>• Existing collet chucks can still be used</li> <li>• Universal toolholder for all sizes</li> <li>• Sealing disc is no longer required – cost and logistics saving</li> </ul>

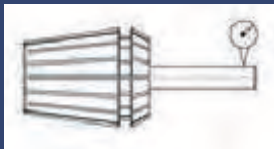

> 10 µm



< 3 µm

**Highest possible run-out and repeatability accuracy.**  
When shrunk in, cutting tool and shrink fit collet form a unit (monoblock) as measured from the face of the collet at 3 x D (diameter of tool shank).

**Result:**  
A very high transmittable torque, best possible run-out properties and highest possible stability



**Increase of tool life for cutting tools up to 300 %**  
Due to the precise clamping of the tool with the TER shrink collets, all cutters enter the workpiece simultaneously, avoiding “knocking” of the cutting edge.

**Result:**  
Better surface finishes & improved accuracy

## TER | ThermoGrip® Collets

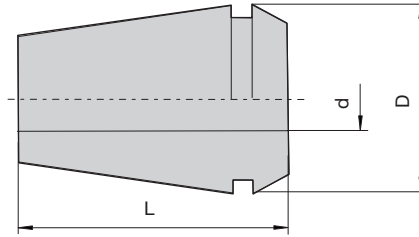

TER – Inch				
SAP No.	Designation	Dimensions (inch)		
		d	D	L
<b>TER11</b>				
5116441	TER0318/11	0.125	0.43	0.71
5116443	TER0476/11	0.180	0.43	0.71
5116444	TER0635/11	0.250	0.43	0.71
<b>TER16</b>				
5059311	TER0318/16	0.125	0.67	1.22
5089047	TER0397/16	0.156	0.67	1.22
5068405	TER0476/16	0.180	0.67	1.22
5059313	TER0635/16	0.250	0.67	1.22
5089048	TER0794/16	0.312	0.67	1.22
5098365	TER0953/16	0.375	0.67	1.22
<b>TER20</b>				
5068413	TER0318/20	0.125	0.83	1.22
5089049	TER0397/20	0.156	0.83	1.22
5068414	TER0476/20	0.187	0.83	1.22
5059315	TER0635/20	0.250	0.83	1.22
5089050	TER0794/20	0.312	0.83	1.22
5059316	TER0953/20	0.375	0.83	1.22
5098366	TER1270/20	0.500	0.83	1.22
<b>TER25</b>				
5068416	TER0318/25	0.125	1.02	1.38
5068417	TER0476/25	0.187	1.02	1.38
5068419	TER0635/25	0.250	1.02	1.38
5068420	TER0953/25	0.375	1.02	1.38
5089052	TER0794/25	0.312	1.02	1.38
5089055	TER1111/25	0.437	1.02	1.38
5060472	TER1270/25	0.500	1.02	1.38
5068421	TER1588/25	0.625	1.02	1.38
<b>TER32</b>				
5059317	TER0635/32	0.250	1.30	1.57
5059318	TER0953/32	0.375	1.30	1.57
5059319	TER1270/32	0.500	1.30	1.57
5060473	TER1588/32	0.625	1.30	1.57
5068422	TER1905/32	0.750	1.30	1.57

TER – Metric				
SAP No.	Designation	Dimensions (mm)		
		d	D	L
<b>TER11</b>				
5076671	TER0300/11	3	11	18
5076673	TER0400/11	4	11	18
5116440	TER0500/11	5	11	18
5076674	TER0600/11	6	11	18
<b>TER16</b>				
5004694	TER0300/16	3	17	31
5004696	TER0400/16	4	17	31
5090498	TER0500/16	5	17	31
5004697	TER0600/16	6	17	31
5004698	TER0800/16	8	17	31
<b>TER20</b>				
5089051	TER0500/20	5	21	31
5004699	TER0600/20	6	21	31
5004700	TER0800/20	8	21	31
5004701	TER1000/20	10	21	31
<b>TER25</b>				
5004702	TER0300/25	3	26	35
5004703	TER0400/25	4	26	35
5089053	TER0500/25	5	26	35
5004705	TER0600/25	6	26	35
5004706	TER0800/25	8	26	35
5004707	TER1000/25	10	26	35
5004708	TER1200/25	12	26	35
5004709	TER1400/25	14	26	35
5004710	TER1600/25	16	26	35
<b>TER32</b>				
5004711	TER0600/32	6	33	40
5004712	TER0800/32	8	33	40
5004713	TER1000/32	10	33	40
5994714	TER1200/32	12	33	40
5004715	TER1400/32	14	33	40
5004717	TER1600/32	16	33	40
5004718	TER1800/32	18	33	40
5004719	TER2000/32	20	33	40

**Basic Adaptor TER with Length Adjustment**



T3-WWK/TER



T3-W/TER

Variable, mechanical length adjustment, precise, adjustable to the required tool length. For all clamping sizes with suitable shrink adaptor. For water cooled shrink units ISG ... TWK and ISG ... WK only the basic adaptor T...-WWK/TER is needed. An additional reduction in combination with the basic holder T...-WWK/TER is required for the table shrink machines ISG 1000 and ISG ... TLK.

SAP No.				Designation
ISG1000	ISG ...TLK	ISG ...TWK	ISG ... WK	
		5020330		T3-WWK/TER
5020330	5020330			T3-WWK/TER
+	+	-	-	+
5020992	5020992			T3-W/TER

**Adaptors for Shrink Fit Collets TER**



For safe holding of the TER shrink fit collet. Suitable for basic adaptor T...-WWK/TER

SAP No.	Designation
5111889	TER 11-2
5111890	TER16-2
5111891	TER20-2
5111892	TER25-2
5111893	TER32-2

**Pole Disc for Shrink Fit Collets TER**



For optimal shielding of the magnetic field between coil and tool shank.

Clamping- Ø	TER size	For ISG2400 Series		For ISG3400 Series	
		SAP No.	Designation	SAP No.	Designation
3-6	ER11	5065479	ISGS2201 TER11/1	5095918	ISGS3201-TER11-1
3-4	ER16	5065474	ISGS2201 TER16/1	5087772	ISGS3201 TER16/1
6-8	ER16	5065477	ISGS2201 TER16/2	5087773	ISGS3201 TER16/2
6-10	ER20	5065473	ISGS2201 TER20/1	5087774	ISGS3201 TER20/1
3-4	ER25	5065468	ISGS2201 TER25/1	5087777	ISGS3201 TER25/1
6-8	ER25	5065470	ISGS2201 TER25/2	5087778	ISGS3201 TER25/2
10-16	ER25	5065472	ISGS2201 TER25/3	5087779	ISGS3201 TER25/3
6-14	ER32	5065466	ISGS2201 TER32/1	5087780	ISGS3201 TER32/1
16-20	ER32	5065467	ISGS2201 TER32/2	5087781	ISGS3201 TER32/2

# CORONA JET THERMOGRIP® HOLDERS



VIEW  
THE  
WEBSITE

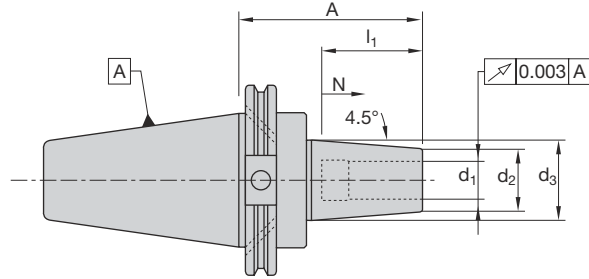

**CAT40 – Inch**

SAP No.	Designation	Dimensions (inch)						
		$d_1$	A	$d_2$	$d_3$	$l_1$	N	g
5102564	T0635-95-C2/CAT40	0.250	3.74	0.83	1.06	1.42	0.39	M5
5102565	T0953-95-C2/CAT40	0.375	3.74	0.95	1.26	1.65	0.39	M8x1
5091566	T1270-95-C2/CAT40	0.500	3.74	1.06	1.34	1.85	0.39	M10x1
5091568	T1588-95-C2/CAT40	0.625	3.74	1.06	1.34	1.97	0.39	M12x1
5091570	T1905-95-C2/CAT40	0.750	3.74	1.30	1.65	2.05	0.39	M16x1

NOTE: All Holders Have 5/8-11 UNC Thread for Retention Knob & DIN FORM B Flange Coolant Delivery Option Standard  
 NOTE: Tool Shank Tolerance must be h6 or better, h4 for holders with ID smaller than 5mm

**CAT50 | ThermoGrip® Corona Jet**

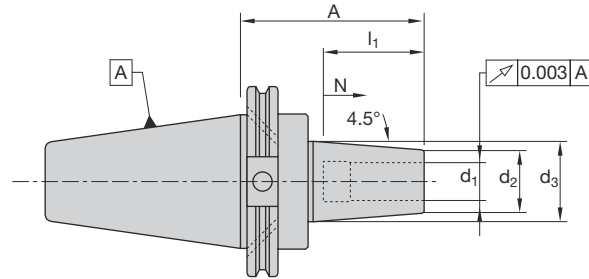

**CAT50 – Inch**

SAP No.	Designation	Dimensions (inch)						
		$d_1$	A	$d_2$	$d_3$	$l_1$	N	g
5090564	T0953-95-C2/CAT50	0.375	3.74	0.95	1.26	1.65	0.39	M8x1
5102566	T1270-95-C2/CAT50	0.500	3.74	1.06	1.34	1.85	0.39	M10x1
5102568	T1588-95-C2/CAT50	0.625	3.74	1.06	1.34	1.97	0.39	M12x1
5102569	T1905-95-C2/CAT50	0.750	3.74	1.30	1.65	2.05	0.39	M16x1

NOTE: All Holders Have 1-8 UNC Thread for Retention Knob & DIN FORM B Flange Coolant Delivery Option-Standard  
 NOTE: Tool Shank Tolerance must be h6 or better, h4 for holders with ID smaller than 5mm

## HSK-F63 | ThermoGrip® Corona Jet

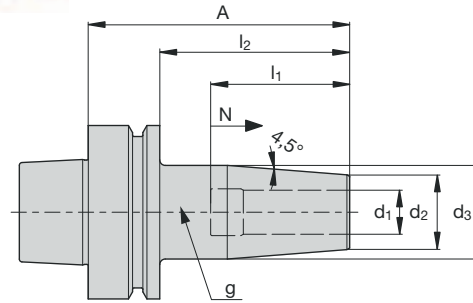

## HSK-F63 – Metric

SAP No.	Designation	Dimensions (mm)							
		d <sub>1</sub>	A	l <sub>2</sub>	d <sub>2</sub>	d <sub>3</sub>	l <sub>1</sub>	N	g
<b>STANDARD PROJECTION</b>									
5102258	T0600-80-C2/HSK-A63	6	90	64	20	27	36	10	M5
5102282	T0800-80-C2/HSK-A63	8	90	64	21	27	36	10	M6
5090843	T1000-85-C2/HSK-A63	10	90	64	24	32	42	10	M8x1
5079124	T1200-90-C2/HSK-A63	12	95	69	24	32	47	10	M10x1
5090846	T1400-90-C2/HSK-A63	14	95	69	27	34	47	10	M10x1
5090849	T1600-95-C2/HSK-A63	16	95	69	27	34	50	10	M12x1
5090852	T1800-95-C2/HSK-A63	18	95	69	33	42	50	10	M12x1
5090855	T2000-100-C2/HSK-A63	20	100	74	33	42	52	10	M16x1
<b>LONG PROJECTION</b>									
5102259	T0600-120-C2/HSK-A63	6	120	94	21	27	36	10	M5
5102273	T0800-120-C2/HSK-A63	8	120	94	21	27	36	10	M6
5090844	T1000-120-C2/HSK-A63	10	120	94	24	32	42	10	M8x1
5079126	T1200-120-C2/HSK-A63	12	120	94	24	32	47	10	M10x1
5090847	T1400-120-C2/HSK-A63	14	120	94	27	34	47	10	M10x1
5090850	T1600-120-C2/HSK-A63	16	120	94	27	34	50	10	M12x1
5090853	T1800-120-C2/HSK-A63	18	120	94	33	42	50	10	M12x1
5090856	T2000-120-C2/HSK-A63	20	120	94	33	42	52	10	M16x1
<b>EXTRA LONG PROJECTION</b>									
5102260	T0600-160-C2/HSK-A63	6	160	134	21	32	36	10	M5
5102274	T0800-160-C2/HSK-A63	8	160	134	21	32	36	10	M6
5090845	T1000-160-C2/HSK-A63	10	160	134	24	34	42	10	M8x1
5079128	T1200-160-C2/HSK-A63	12	160	134	24	34	47	10	M10x1
5090848	T1400-160-C2/HSK-A63	14	160	134	27	42	47	10	M10x1
5090851	T1600-160-C2/HSK-A63	16	160	134	27	42	50	10	M12x1
5090854	T1800-160-C2/HSK-A63	18	160	134	33	51	50	10	M12x1
5090857	T2000-160-C2/HSK-A63	20	160	134	33	51	52	10	M16x1

All holders can be run with internal coolant

NOTE: Tool Shank Tolerance must be h6 or better, h4 for holders with ID smaller than 5mm



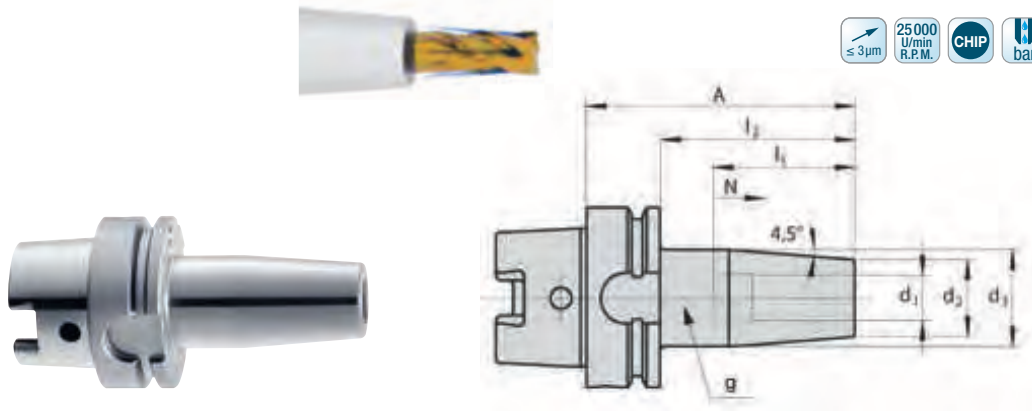

HSK-A63 – Inch		Dimensions (inch)						
SAP No.	Designation	d <sub>1</sub>	A	d <sub>2</sub>	d <sub>3</sub>	l <sub>1</sub>	N	g
5090450	T0635-80-C2/HSK-A63	0.250	3.15	0.83	1.06	1.42	0.39	M5
5090451	T0953-85-C2/HSK-A63	0.375	3.34	0.95	1.26	1.65	0.39	M8x1
5090452	T1270-90-C2/HSK-A63	0.500	3.54	1.06	1.34	1.85	0.39	M10x1
5102570	T1588-95-C2/HSK-A63	0.625	3.74	1.06	1.34	1.97	0.39	M12x1
5090453	T1905-100-C2/HSK-A63	0.750	3.94	1.30	1.65	2.05	0.39	M16x1

All holders can be run with internal coolant  
 Please Order Coolant Tube Catalog No. HSK63-18 separately  
 NOTE: Tool Shank Tolerance must be h6 or better, h4 for holders with ID smaller than 5mm

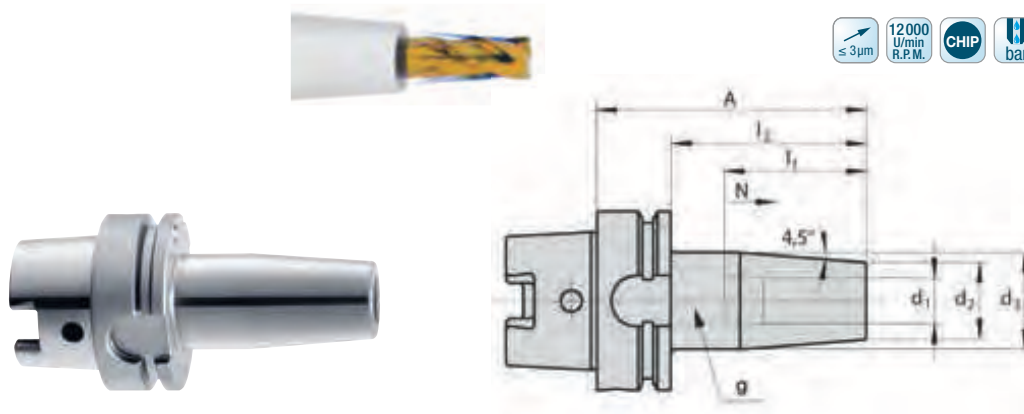

HSK-A100 – Metric		Dimensions (mm)						
SAP No.	Designation	d <sub>1</sub>	A	d <sub>2</sub>	d <sub>3</sub>	l <sub>1</sub>	N	g
5113935	T0600-85-C2/HSK-A100	6	85	21	27	36	10	M5
5113938	T0800-85-C2/HSK-A100	8	85	21	27	36	10	M6
5113939	T1000-90-C2/HSK-A100	10	90	24	32	42	10	M8x1
5107692	T1200-95-C2/HSK-A100	12	95	24	32	47	10	M10x1

All holders can be run with internal coolant  
 Please Order Coolant Tube Catalog No. HSK100-24 separately  
 NOTE: Tool Shank Tolerance must be h6 or better, h4 for holders with ID smaller than 5mm

# JET SLEEVE™ COOLANT SYSTEM

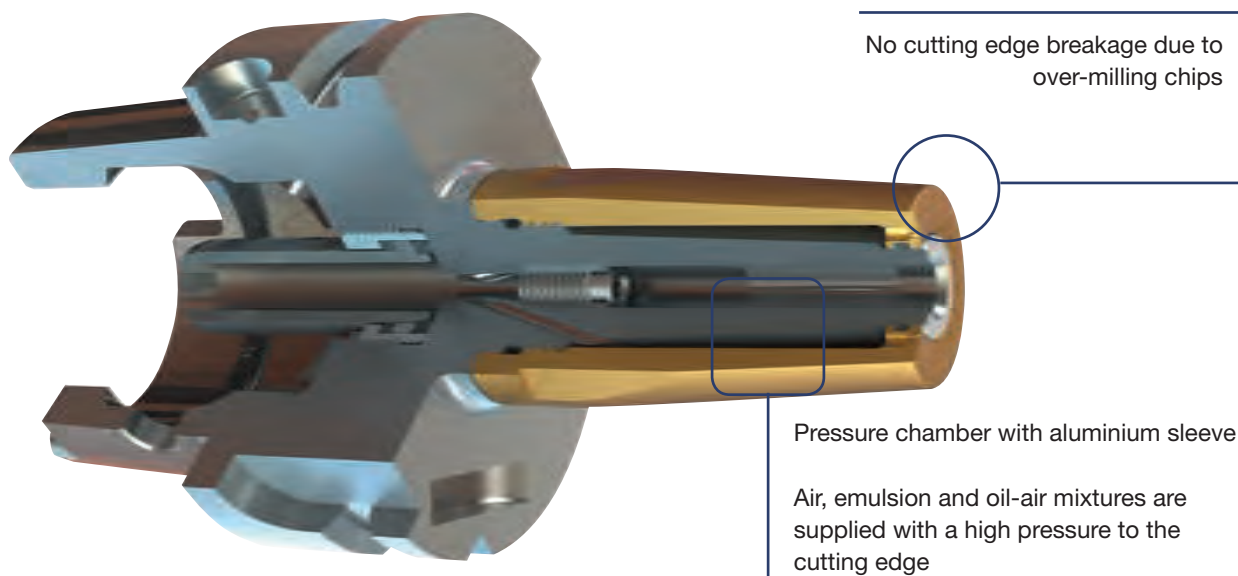

The JetSleeve® shrink-fit holder are available in two versions:

**Slim Version – JetSleeve®**  
holder without aluminium sleeve  
corresponds to the slim  
geometry TSF...

**Reinforced version – JetSleeve®**  
holder without aluminium sleeve  
corresponds to the standard geometry T...

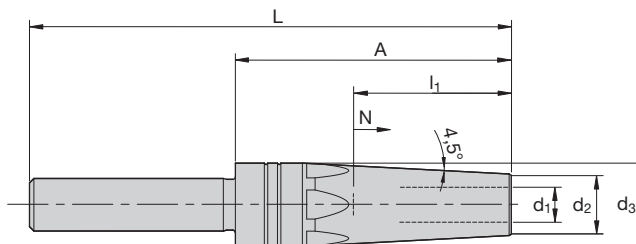

## TJSV Straight Shank – Inch

SAP No.	Designation	Dimensions (inch)						
		d <sub>1</sub>	d <sub>2</sub>	d <sub>3</sub>	L	A	N	g
5050769	TJSV0318-60/1588	0.125	0.59	0.79	4.33	2.36	0.39	M6
5050771	TJSV0635-60/1588	0.250	0.83	1.06	4.33	2.36	0.39	M5
5050772	TJSV0953-60-1905	0.375	0.94	1.26	4.33	2.36	0.39	M8x1
5050773	TJSV1270-60/1905	0.500	1.06	1.34	4.33	2.36	0.39	M10x1
5050774	TJSV0625-60/1905	0.625	1.06	1.34	4.33	2.36	0.39	M12x1

All holders can be run with internal coolant

NOTE: Tool Shank Tolerance must be h6 or better, h4 for holders with ID smaller than 5mm

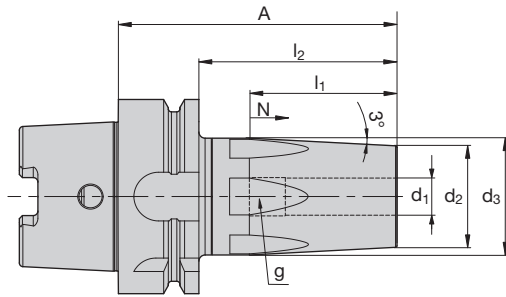
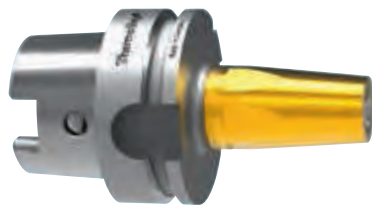

**TJS HSK-A63 Standard JetSleeve – Inch**

SAP No.	Designation	Dimensions (inch)							Ring Wrench
		d <sub>1</sub>	d <sub>2</sub>	d <sub>3</sub>	l <sub>1</sub>	A	N	g	
5060494	TJS0953/HSK-A63	0.375	1.10	1.34	1.65	3.35	0.39	M8x1	32
5060496	TJS1270/HSK-A63	0.500	1.30	1.50	1.85	3.54	0.39	M10x1	36
5060497	TJS1905/HSK-A63	0.750	1.73	2.01	2.05	3.94	0.67	M16x1	50

**TJSS HSK-A63 Slim JetSleeve – Inch**

SAP No.	Designation	Dimensions (inch)							Ring Wrench
		d <sub>1</sub>	d <sub>2</sub>	d <sub>3</sub>	l <sub>1</sub>	A	N	g	
5060485	TJSS0318/HSK-A63	0.125	0.59	0.79	0.79	3.15	0.35	M6	19
5060487	TJSS0635/HSK-A63	0.250	0.79	1.06	1.42	3.15	0.35	M5	25
5060488	TJSS0953/HSK-A63	0.375	0.95	1.26	1.42	3.35	0.20	M8x1	30
	TJSS1270/HSK-A63	0.500	0.95	1.26	1.85	3.54	0.35	M10x1	30

All holders can be run with internal coolant  
Please Order Coolant Tube Catalog No. HSK63-18 separately

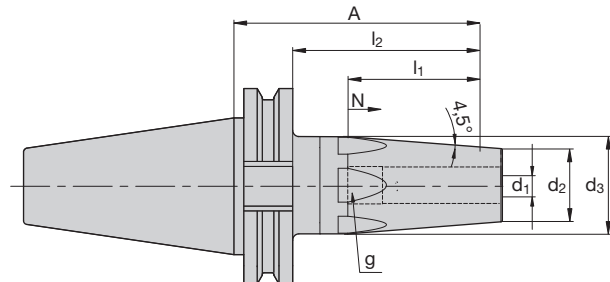

**TJS CAT50 Standard JetSleeve – Inch**

SAP No.	Designation	Dimensions (inch)							Ring Wrench
		d <sub>1</sub>	d <sub>2</sub>	d <sub>3</sub>	l <sub>1</sub>	A	N	g	
5062767	TJS0953-95/CAT-50	0.375	1.10	1.34	1.65	3.74	0.39	M8x1	32
82.306.509.410	TJS1270-95/CAT-50	0.500	1.30	1.50	1.85	3.74	0.39	M10x1	36
82.306.509.590	TJS1905-95/CAT-50	0.750	1.73	2.01	2.05	3.74	0.67	M16x1	50

**TJSS CAT40 Slim JetSleeve – Inch**

SAP No.	Designation	Dimensions (inch)							Ring Wrench
		d <sub>1</sub>	d <sub>2</sub>	d <sub>3</sub>	l <sub>1</sub>	A	N	g	
5060477	TJSS0318/CAT40	0.125	0.59	0.79	0.79	3.15	0.35	M6	19
5060480	TJSS0635/CAT40	0.250	0.83	1.06	1.42	3.15	0.35	M5	25
5060483	TJSS0953/CAT40	0.375	0.95	1.26	1.65	3.15	0.35	M8x1	30
5063935	TJSS1270/CAT40	0.500	0.95	1.26	1.85	3.77	0.28	M10x1	30

**TJSS CAT50 Slim JetSleeve – Inch**

SAP No.	Designation	Dimensions (inch)							Ring Wrench
		d <sub>1</sub>	d <sub>2</sub>	d <sub>3</sub>	l <sub>1</sub>	A	N	g	
82.306.508.110	TJSS0635-95/CAT-50	0.250	0.83	1.06	1.42	3.74	0.39	M6	25
82.306.508.280	TJSS0953-95/CAT-50	0.375	0.95	1.26	1.65	3.74	0.39	M8x1	30

All holders can be run with internal coolant  
NOTE: Tool Shank Tolerance must be h6 or better, h4 for holders with ID smaller than 5mm

# MQL MINIMUM QUANTITY LUBRICANT TECHNOLOGY

## IMPROVED COOLANT DELIVERY REDUCES COSTS

Minimum Quantity Lubricant (MQL) technology represents a significant improvement in the delivery of coolant during machining. Applications which once required 1,000's of gallons of coolant in circulation can now be done with just a few ounces of lubricant per hour for each spindle. You'll spend far less on coolant while also improving work environment and safety.

- Huge reductions in coolant consumption
- Environmentally friendly
- Up to 100% increase in tool life

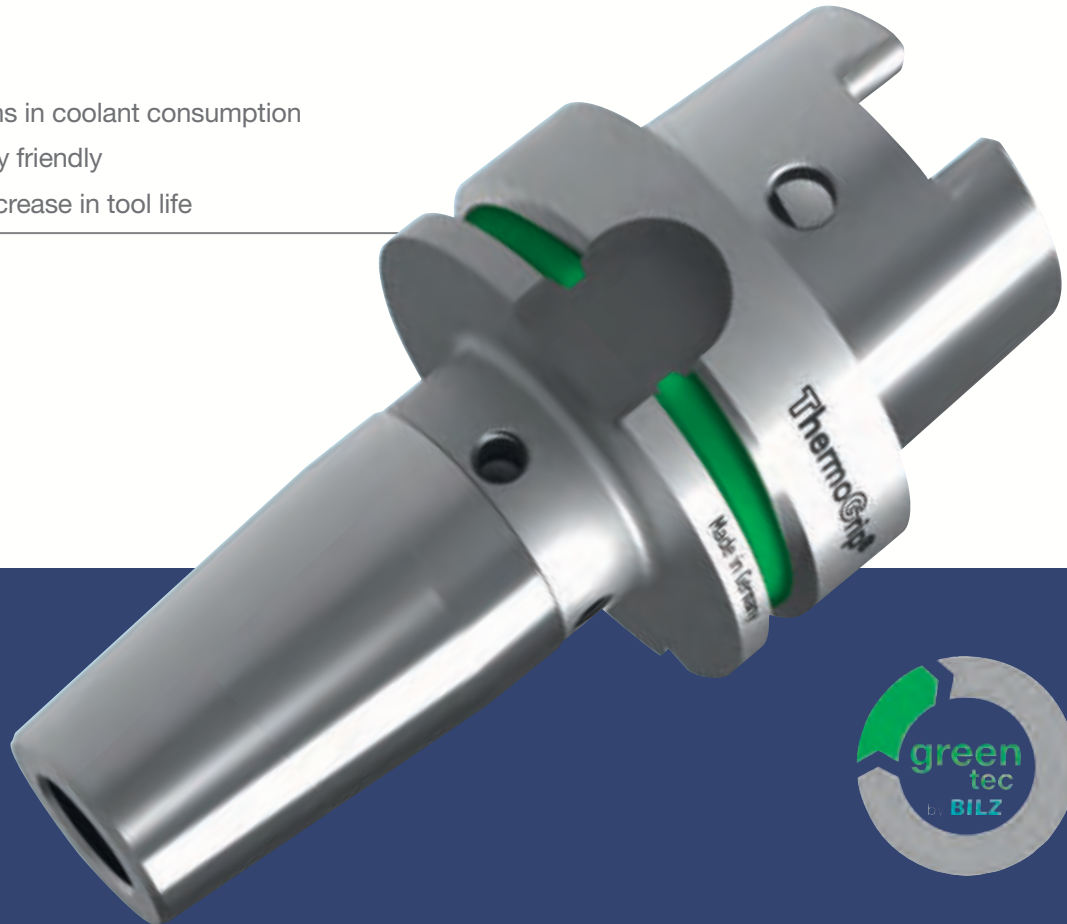

VIEW  
THE  
WEBSITE

**MQL MINIMUM QUANTITY LUBRICANT TECHNOLOGY**

**1** 1-channel system licence of Horkos Corp.

**2** 2-channel system

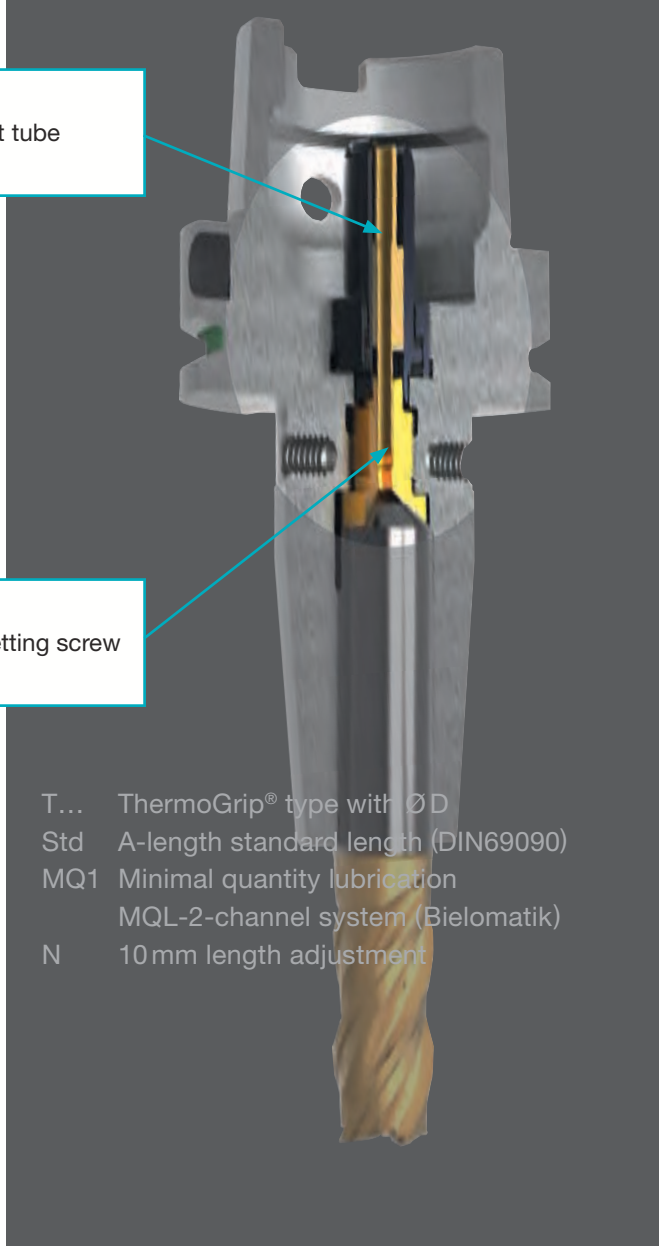
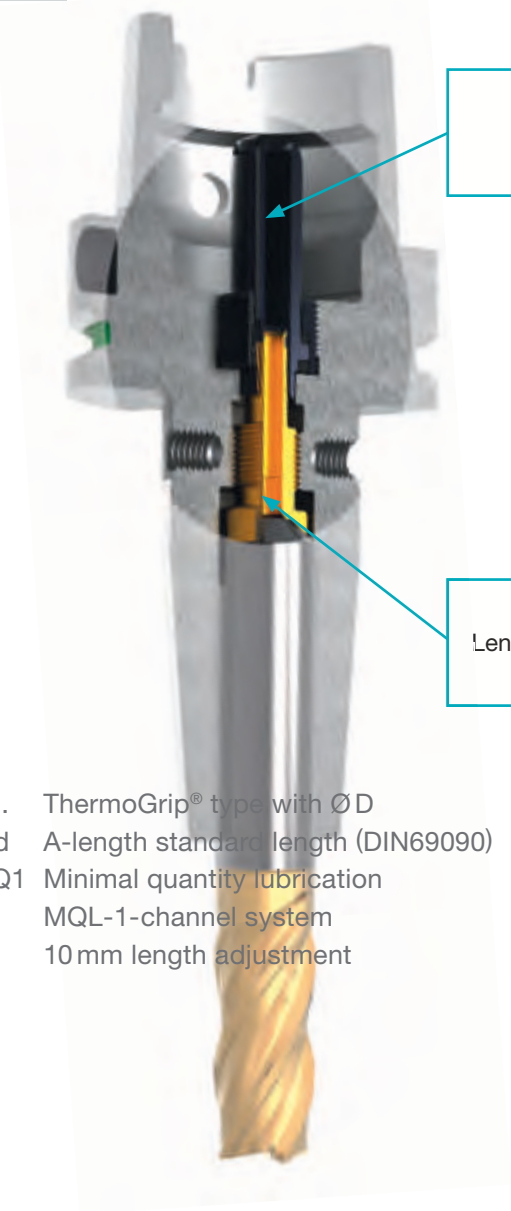

Coolant tube

Length presetting screw

T... ThermoGrip® type with ØD  
 Std A-length standard length (DIN69090)  
 MQ1 Minimal quantity lubrication  
 MQL-1-channel system  
 N 10mm length adjustment

T... ThermoGrip® type with ØD  
 Std A-length standard length (DIN69090)  
 MQ1 Minimal quantity lubrication  
 MQL-2-channel system (Bielomatik)  
 N 10mm length adjustment

# HARDWARE



T – Adjusting Screws							
SAP No.	Designation	for bore size (mm)	Shrink depth	Thread	Screw dimension	Adjustment	SW
6954747	BN158-0616-1.5	3	20	M6	M6x16	10	3
6946782	BN158-0610	4	20	M6	M6x10	10	3
6946782	BN158-0610	5	25	M6	M6x10	10	3
6947302	T0600-2-M5x18	6	36	M5	M5x18	10	2.5
6947303	T0800-2-M6x20	8	36	M6	M6x20	10	3
6952015	T1000-2-M8x1x20	10	42	M8x1	M8x20	10	4
6952015	T1000-2-M8x1x20	11	47	M8x1	M8x20	10	5
6952444	T1200-2-M10x1x15	12	47	M10x1	M10x15	10	5
6952444	T1200-2-M10x1x15	14	47	M10x1	M10x15	10	5
6952017	T1600-2-M12x1x20	15	50	M12x1	M12x20	10	6
6952017	T1600-2-M12x1x20	16	50	M12x1	M12x20	10	6
6952017	T1600-2-M12x1x20	18	50	M12x1	M12x20	10	6
6952018	T2000-2-M16x1x20	20	52	M16x1	M16x20	10	8
6952018	T2000-2-M16x1x20	22	52	M16x1	M16x20	10	8
6952018	T2000-2-M16X1x20	25	58	M16x1	M16x20	10	8
6952018	T2000-2-M16X1x20	28	62	M16x1	M16x20	10	8
6952018	T2000-2-M16X1x20	32	62	M16x1	M16x20	10	8

TSF – Adjusting Screws							
SAP No.	Designation	for bore size (mm)	Shrink depth	Thread	Screw dimension	Adjustment	SW
6954747	BN158-0616-1.5	3	20	M6	M6x16	5	3
6946782	BN158-0610	4	20	M6	M6x10	5	3
6946782	BN158-0610	5	25	M6	M6x10	5	3
6952890	T0600-2-M5x18	6	36	M5	M5x15	5	2.5
6950028	T0800-2-M6x16	8	36	M6	M6x16	5	3
6952442	T1000-2-M8x1x15	10	42	M8x1	M8x15	5	4
6952444	T1200-2-M10x1x15	12	47	M10x1	M10x15	5	5
6952444	T1200-2-M10x1x15	14	47	M10x1	M10x15	5	5
6952445	T1600-2-M12x1x15	16	50	M12x1	M12x15	5	6
6952017	T1600-2-M12x1x20	18	50	M12x1	M12x20	5	6
6952529	T2000-2-M16x1x20	20	52	M16x1	M16x15	5	8
6952529	T2000-2-M16x1x20	25	58	M16x1	M16x15	5	8

THD – Adjusting Screws							
SAP No.	Designation	for bore size (mm)	Shrink depth	Thread	Screw dimension	Adjustment	SW
6952017	T1600-2-M12x1x20	16	50	M12x1	M12x20	10	6
6952018	T2000-2-M16x1x20	20	52	M16x1	M16x20	10	8
6952018	T2000-2-M16x1x20	25	58	M16x1	M16x20	10	8
6952018	T2000-2-M16x1x20	32	62	M16x1	M16x20	10	8

## Assembly Instructions Coolant Transfer Set

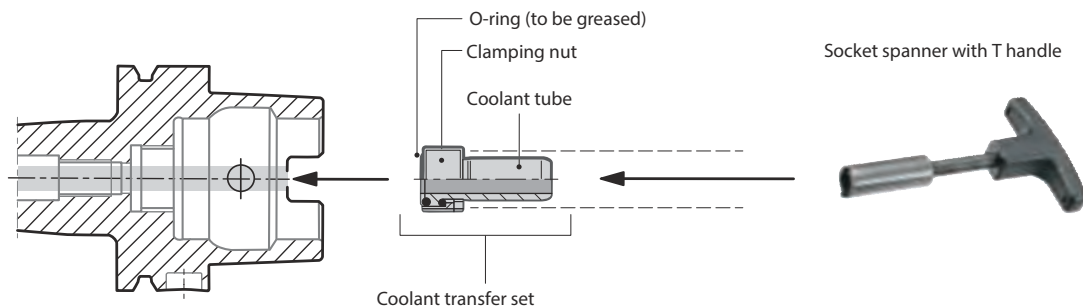

1. The HSK shank must be clean and free from swarf and damage
2. Grease the O-rings before assembly.
3. Completely insert the coolant transfer set (coolant tube, clamping nut and 2 O-rings) centrally into the HSK.
4. Screw in the coolant transfer set/unit.
5. Check the coolant tube for radial movement.

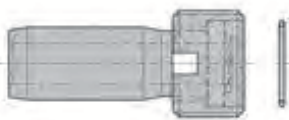

## Coolant Pipe

Size	Designation	Ident No.
HSK25	UE4 HSK25	5100005
HSK32	UE4 HSK32	5064893
HSK40	UE4 HSK40	5028425
HSK50	UE4 HSK50	5028426
HSK63	UE4 HSK63	5025376
HSK80	UE4 HSK80	5028427
HSK100	UE4 HSK100	5028428
HSK125	UE4 HSK125	5064893

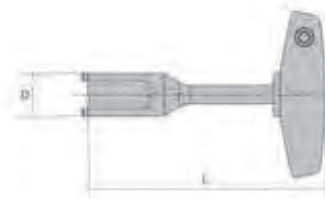

## Installation Wrench for Coolant Pipe

Size	D [mm]	L [mm]	Max. Torque [Nm]	Ident No.
HSK32	6,8	132	3	5100007
HSK32	8,5	115	7	6738740
HSK40	10,5	115	11	6738741
HSK50	14,5	115	15	6738422
HSK63	16,5	136	20	6738421
HSK80	18,5	136	25	6738095
HSK100	22,0	136	30	6738303

For coolant transfer for HSK tools incl. round gasket DIN 3770 and union nut.



# TECHNICAL

## BILZ QUALITY FEATURES

**MADE IN GERMANY:** All tool holders are manufactured in a temperature controlled environment in Ostfildern-Nellingen and in the factory in Horb-Betra which is near the black forest.

**MATERIAL:** We use high-tensile heat-treated steel, heat resistant steel or special purpose steel with minimally tolerated alloy parts. Tensile strength in the core > 900 N/mm<sup>2</sup>.

**HARDENING:** The hardening process and the hardening depth are harmonised with the corresponding chuck type and size, so that even thin-walled HSK-tapers do not full-harden. The risk of breaking or cracking can be virtually eliminated.

**DESIGN:** Tool surface is eco-friendly blasted with chilled iron and protected against corrosion. Hollow taper shanks are ground with precision  $Ra \leq 0.2$ . Holder sides are ground with precision  $Ra \leq 0.4$ . Shrink chucks HSK-E and HSK-F as well as mold makers' shrink chucks TSF are non-corrosion coated.

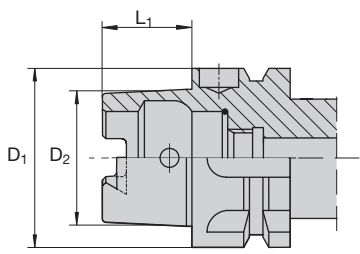
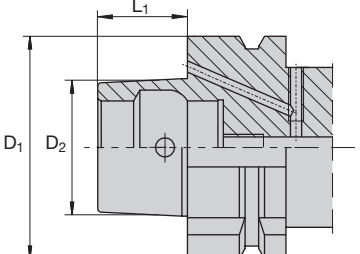
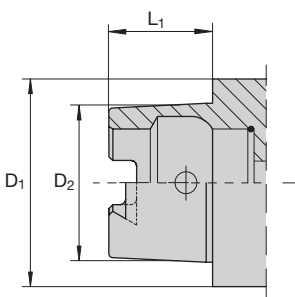
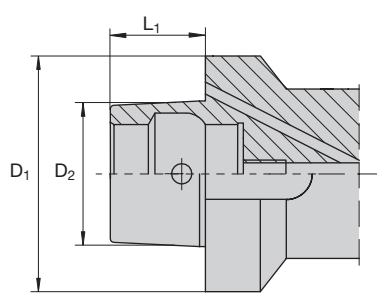
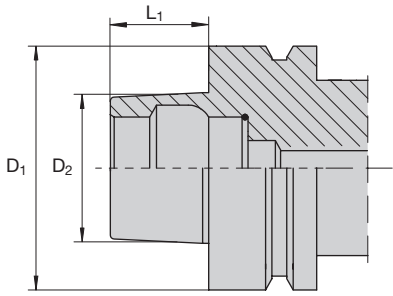
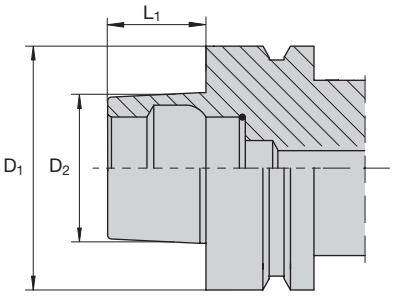
<b>Shape A</b> 			<b>Shape B</b> 		
<p>Hollow-shank taper for automatic tool changing with gripping and locating groove. Manual operation is possible through the access hole in the taper. Torque is transmitted both positively and non-positively.</p>					
<b>Shape C</b> 			<b>Shape D</b> 		
<p>Hollow-shank taper for manual tool changing. Operation is possible through the access hole in the taper. Torque is transmitted both positively and non-positively.</p>					
<b>Shape E</b> 			<b>Shape F</b> 		
<p>Hollow-shank taper for automatic tool changing (manual operation through access hole in taper not possible). Torque is transmitted non-positively.</p>					
<b>HSK Shape A, C, E</b>			<b>HSK Shape B, D, F</b>		
<b>Nominal Size</b> <b>D<sub>1</sub> (mm)</b>	<b>D<sub>2</sub> (mm)</b>	<b>L<sub>1</sub> (mm)</b>	<b>Nominal Size</b> <b>D<sub>1</sub> (mm)</b>	<b>D<sub>2</sub> (mm)</b>	<b>L<sub>1</sub> (mm)</b>
25	19	13	—	—	—
32	24	16	—	—	—
40	30	20	40	24	16
50	38	25	50	30	20
63	48	32	63	38	25
80	60	40	80	48	32
100	75	50	100	60	40

**Hollow Shank Taper 1264-1**

**Balancing:**

All Bilz HSK tool holders are design prebalanced and fine-balanced to the best possible and reproducible balancing quality after grinding.

HSK-A	HSK-C	HSK-E	HSK-F
< 1.6 gmm/kg	< 1.6 gmm/kg	< 1.0 gmm/kg	< 1.0 gmm/kg

**Tool Holders Taper ISO 7388-1**

**Balancing quality:**

All Bilz ISO tool holders are design prebalanced and fine-balanced to the highest possible reproducible balancing quality < 1.6 gmm/kg after grinding.

CAT 40	CAT 50	BT 30	BT 40
< 1.6 gmm/kg	< 1.6 gmm/kg	< 1.6 gmm/kg	< 1.6 gmm/kg

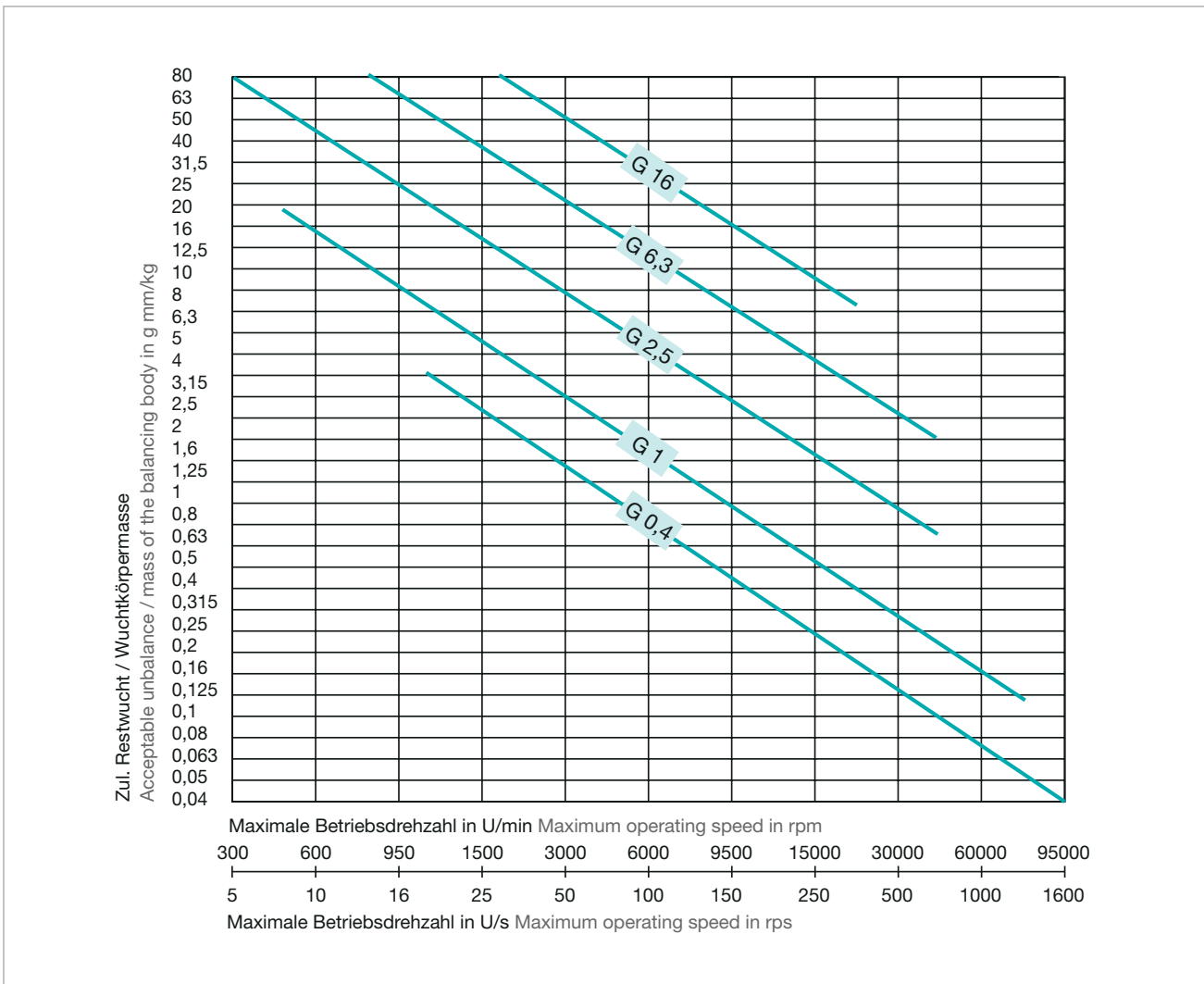

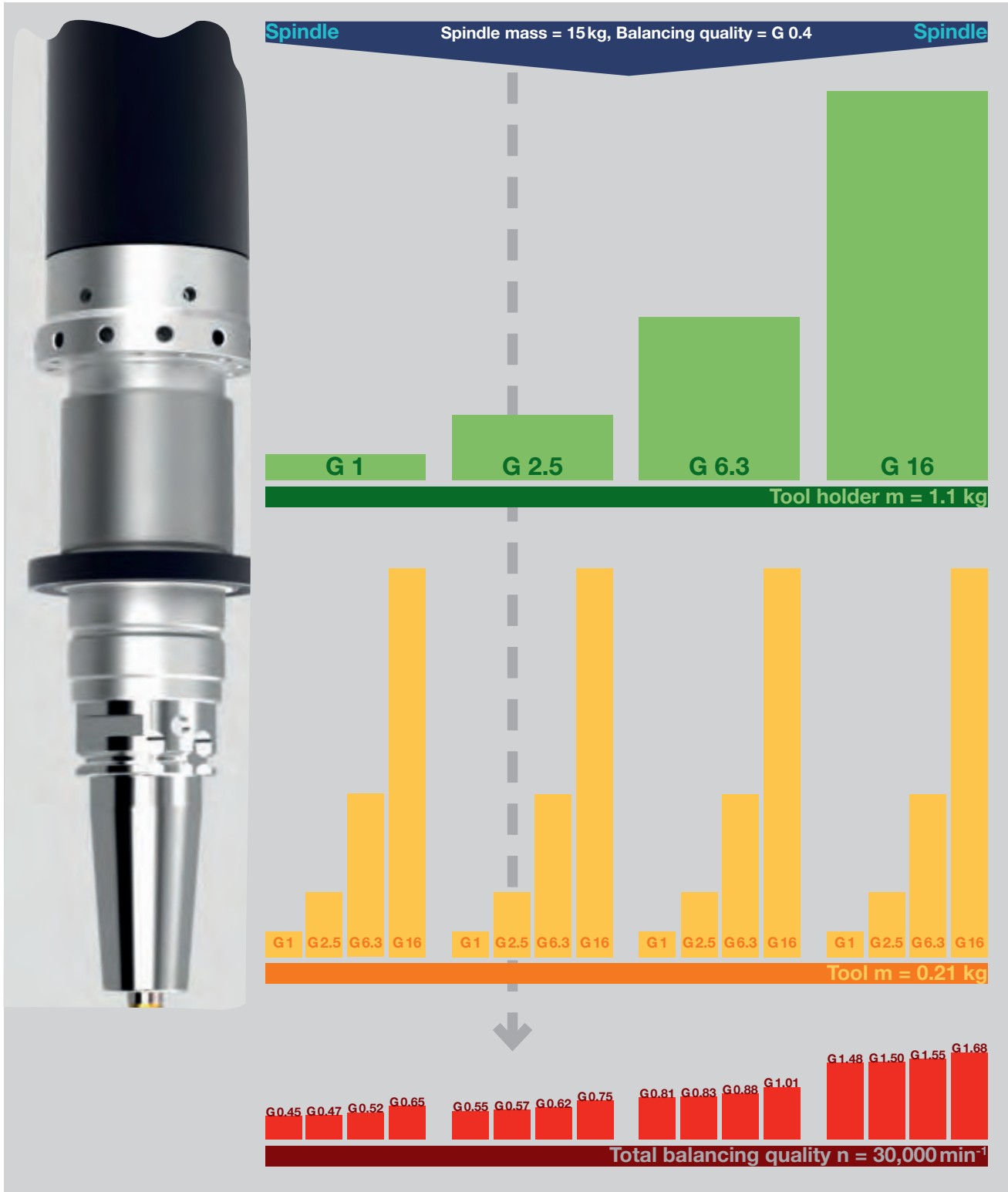

diameter range		tolerances				examples
dimensions in (mm)		h4	h5	h6	h7	
from to	1 3	0 -0.003	0 -0.004	0 -0.006	0 -0.010	for our 3mm ThermoGrip holder
above to	3 6	0 -0.004	0 -0.005	0 -0.008	0 -0.012	for our 5mm ThermoGrip holder
above to	6 10	0 -0.004	0 -0.006	0 -0.009	0 -0.015	for our 1/4" ThermoGrip holder
above to	10 18	0 -0.005	0 -0.008	0 -0.011	0 -0.018	
above to	18 30	0 -0.006	0 -0.009	0 -0.013	0 -0.021	for our 3/4" ThermoGrip holder
above to	30 50	0 -0.007	0 -0.011	0 -0.016	0 -0.025	
above to	50 65	0 -0.008	0 -0.013	0 -0.019	0 -0.030	

## Tool Clamping Options and Values | Technical Information

CHARACTERISTIC	END MILL HOLDER	DA COLLET CHUCKS	SC COLLET CHUCKS	ER COLLET CHUCKS
<b>PRECISION</b> Toolholder precision is based on run out or TIR from centerline on rotation axis at the shank and cutting tool tip/edge	<b>1</b> Lowest precision due to bore tolerances, diametrical clearance and side lock screw forces.	<b>1</b> Lower precision due to design and gripping accuracy.	<b>2</b> Single angle design lends itself to high gripping strength and accuracy.	<b>3</b> Highest single angle collet accuracy and solid carbide tool shank grip.
<b>VERSATILITY</b> Expanse of use is based on the capability to clamp multiple tool shank diameters and styles	<b>1</b> One size per tool limited to same size tool shank.	<b>3</b> The DA (double angle) collet system has three collet size ranges accommodating shank sizes to 3/4" maximum diameter.	<b>5</b> SC (PG or TG) single angle collet systems have three series sizes accommodating tool shank sizes to a maximum of 1.500" diameter tool shank.	<b>5</b> ER collet system is based on metric nominal sizes and has a tool angle different than the SC collet system. ER collets are available in six different sizes and can accommodate tool shanks to a maximum of 1.181" diameter shank.
<b>TOOL CLAMPING RIGIDITY</b> How rigid is the cutting tool shank secured in the body of the holder under cutting tool loads and RPM changes.	<b>1</b> Minimal rigidity due to set screw design clamp cutting tool shank off center.	<b>2</b> Median tool rigidity due to limit tool shank clamping force of DA collet design.	<b>4</b> Best collet grip strength due to design. 3 to 1 torque value on tool shank.	<b>3</b> Good collet grip strength due to design. 2 to 1 torque value on tool shank.
<b>EASE OF USE</b> Ease of use is based on the simplicity of the "clamping system" to be assembled and disassembled with the cutting tools.	<b>4</b> 1 or 2 set screws required to secure tool shank in tool holder.	<b>3</b> May assemble tool, collet and collet nut in any sequence.	<b>2</b> Requires collet to be inserted in collet nut before tool shank can be inserted into collet and then into tool holder body.	<b>2</b> Requires collet to be inserted in collet nut before tool shank can be inserted into collet and then into tool holder body.
<b>RELIABILITY</b> How reliable is the "clamping system" to maintain the required optimal precision for the assembled system.	<b>3</b> End mill holders require minimal maintenance other than ID bore integrity.	<b>3</b> Regular cleaning of collet surface and collet body surfaces. Care of collets is most critical.	<b>3</b> Regular cleaning of collet surface and collet body surfaces. Care of collets is most critical.	<b>3</b> Regular cleaning of collet surface and collet body surfaces. Care of collets is most critical.
<b>HIGH RPM/ TOOL BALANCE</b> As machining RPM increase, tool balance is important. Value based on ability to maintain tool balance at high RPM.	<b>1</b> End mill holders by design are unbalanced and unstable at high RPM.	<b>1</b> Lack of collet precision design and collet nut design makes DA system weak at high RPM.	<b>2</b> Concentric collet and collet body design allow for moderate RPM use but collet nut design limits high RPM usage.	<b>3</b> Concentric collet and collet body design allow for moderate RPM use but collet nut design limits high RPM usage.
<b>ECONOMY/COST</b> Cost or purchased value of the tool clamping system.	<b>5</b> Lowest cost tool holder system.	<b>4</b> Lowest cost collet system due to lower precision system.	<b>4</b> Median price tool holding system but must secure collet as well TG/PG collets price similar to ER collets.	<b>3</b> Median price tool holding system but must secure collet as well TG/PG collets price similar to ER collets.
<b>VALUE</b> Value of the productivity and tool performance gained from the assembled system.	<b>1</b> While the most economical purchase, this tool style can be the most costly due to it's low TIR and limited applications of tool sizes and RPM capabilities.	<b>2</b> While this was the "original collet chuck system" it is limited in its accuracy and rigidity. It is great for narrow clearances and drilling applications.	<b>2</b> This product was the 2nd generation of collet systems and is widely used today. Its gripping strength is the highest of SC or ER collet systems. One issue still remains and that is the shank engagement required for carbide shank tools.	<b>3</b> The most flexible and accurate of the collet systems that are considered "industry standard" today. Good tool shank gripping strength and high accuracy with regards to TIR.

HP COLLET CHUCKS	MILLING CHUCKS	HYDRAULICS CHUCKS	SHRINK FIT	CHARACTERISTIC
4	4	5	5	<b>PRECISION</b> Toolholder precision is based on run out or TIR from centerline on rotation axis at the shank and cutting tool tip/edge
Highest single angle collet accuracy with close tolerance collet ID sizes for TIR improvement	Precision achieved is based on collet accuracy and torque value of assembled system	High TIR accuracy due to system design and manufacturing tolerances to rotational centerline	Highest TIR accuracy of all clamping systems.	
4	4	1	1	<b>VERSATILITY</b> Expanse of use is based on the capability to clamp multiple tool shank diameters and styles
Same as ER collet system but with highest TIR accuracy through a controlled manufacturing process.	Reduction collet system designed to operate in conjunction with the roller bearing clamping system design in the collet nut	Single size ID per tool clamping system. Accommodates a single shank size	Single size ID that accommodates a single size tool shank requiring H6 or H7 shank tolerance	
3	4	4	5	<b>TOOL CLAMPING RIGIDITY</b> How rigid is the cutting tool shank secured in the body of the holder under cutting tool loads and RPM changes.
Good collet grip strength due to design. 2 to 1 torque value on tool shank. Collet collapse restriction limits rigidity	Strongest gripping collet system. Gripping strength is nearest thermal clamping strength	Good clamping rigidity for “Z” axis use only. Radial loads can damage internal hydraulic sleeve design.		
1	3	2	4	<b>EASE OF USE</b> Ease of use is based on the simplicity of the “clamping system” to be assembled and disassembled with the cutting tools.
Requires collet to be inserted in collet nut before tool shank can be inserted into collet and then into tool holder body. HP ER collets have limited collet collapse range.	Reduction collet system.	Tool insertion is completed and then pressure clamp screw is adjusted to increase “hydraulic” clamp forces surrounding the sleeve holding the tool shank.	Requires shrink fit machine to heat the tool clamping bore allowing tool shank insertion.	
4	4	4	5	<b>RELIABILITY</b> How reliable is the “clamping system” to maintain the required optimal precision for the assembled system.
Regular cleaning of collet surface and collet body surfaces. Care of collets is most critical.	Regular cleaning of collet surface and collet body surfaces. Care of collets is most critical.	Regular cleaning of bore required. Only solid and cylindrical shanks with no voids can be used in this system.	No mechanical parts to wear out or be maintained.	
4	3	4	5	<b>HIGH RPM/ TOOL BALANCE</b> As machining RPM increase, tool balance is important. Value based on ability to maintain tool balance at high RPM.
Concentric collet and collet body design allow for moderate RPM use but collet nut design limits high RPM usage.	Concentric collet and collet body design allow for moderate RPM use but collet nut design limits high RPM usage.	Body design and “fluid clamping” system limits high RPM usage.	No mechanical parts and designed for balance stability at high RPM.	
2	2	5	3	<b>ECONOMY/COST</b> Cost or purchased value of the tool clamping system.
Median price tool holding system but must secure collet. HP (PG/TG HP or ER HP) are higher cost than standard collets.	Higher cost of holder due to design and clamping system.	Most expensive tool clamping system.	Median price of tool holder but shrink fit machine needs to be purchased to support the system.	
4	4	3	5	<b>VALUE</b> Value of the productivity and tool performance gained from the assembled system.
Same as the ER collet system but with higher TIR accuracy. Much more costly collets than standard ER style collets.	Great tool shank gripping strength and excellent TIR accuracy. Excellent value for large shank tools and high radial tool loads when using heavy feed rates. Large nose limits clearances in pockets.	Highest accuracy for “Z” axis drilling. Expensive tool that usually needs replacement every 3- 5 years. Limited uses for end milling as radial loads must be light to reduce risk of damaging holder bore.	After investment is made, this system offers all the productivity benefits for milling, drilling, and reaming. Most rigid, highest TIR accuracy, and best tool gripping strength of all clamping systems. Best overall value when considering tooling cost with productivity and part accuracy achievements.	

# Bilz ThermoGrip® Technology

Bilz ThermoGrip technology began in 1998 with the introduction of our first induction coil shrink fit product. Since this date, Bilz has been a market-leader in shrink fit technology innovation and development under the brand name “ThermoGrip”. Bilz is committed to continuous improvement and development of the shrink fit technology utilizing the induction coil technology for tool clamping.

As Bilz continues into the 21st Century, we are committed to further development and improvement of the ThermoGrip shrink fit technology as we strive to make the system more efficient, higher quality, and more energy efficient. ThermoGrip technology has proven it is the right tool clamping system for every cutting tool application where maximum productivity, highest part finish, and lower manufacturing cost are your goals.

With the Bilz ThermoGrip system, it is all about the centerline on the “tool unit” – tool clamping and cutting tool assembly, in other words optimization of cutting parameters through the accurate cutting edge flight path.

## KEYS BENEFITS OF THE BILZ THERMOGRIP TOOL CLAMPING SYSTEM:

- Most accurate TIR of any tool clamping system
- Highest quality tool product material
- Most accurate grind – Bore, Outside Dimensions, and taper
- Most accurate and tightest tool clamping bore in diameter, axial run-out, and bore tolerance
- Induction Coil Technology
- Broadest product offering – shanks, gage lengths, styles, bore diameters
 

“T” STYLE	“TSF” STYLE	“THD” STYLE	“TSFV” STYLE	“TER” STYLE	JETSLEEVE
Standard	Slimline	Heavy-duty	Slimline Extension	Thermo ER collet	New Innovation
- Fastest shrink and cooling cycle time in the market – Liquid Emulsion system
- Highest balance standard of all shrink fit technology  
12,000rpm to 42,000rpm depending on shank taper size and style
- Ease of use – ease of operation  
Operator safety – no “hot” chucks to handle – safest system on the market  
Liquid Emulsion guarantees cold tool  
Not contact with cooling adapters and cutting tool edges
- Highest cutting tool rigidity of any tool clamping system  
No moving parts, no mechanical connection
- Use with High Speed Steel shank and/or Carbide shank cutting tools  
Bilz patented Pole Disc and Bilz patented ID Counterbore allows Bilz ThermoGrip to shrink both shank materials. More importantly it allows the user to extract the used cutting tool from the shrink chuck; this is not always guaranteed from other manufacturers who do not benefit from the patented counter-bore.

## WHY BILZ THERMOGRIP TECHNOLOGY FOR YOUR MANUFACTURING APPLICATIONS?

- Longer cutting tool life
- Improved workpiece surface finish quality
- Machine spindle friendly – less wear on machine spindles  
Best tool balance of any clamping system on the market  
Reduce/eliminate spindle/tool harmonics
- Maintenance of machining tolerances for longer periods  
Strongest tool rigidity – reduce cutting tool wear, increased cutting tool life  
Most accurate TIR – rotational accuracy unsurpassed by any other mechanical clamping system  
Maximized operator safety, never any contact with hot chucks!



MOST ACCURATE AND TIGHTEST TOOL CLAMPING BORE IN DIAMETER, AXIAL RUN-OUT, AND BORE TOLERANCE

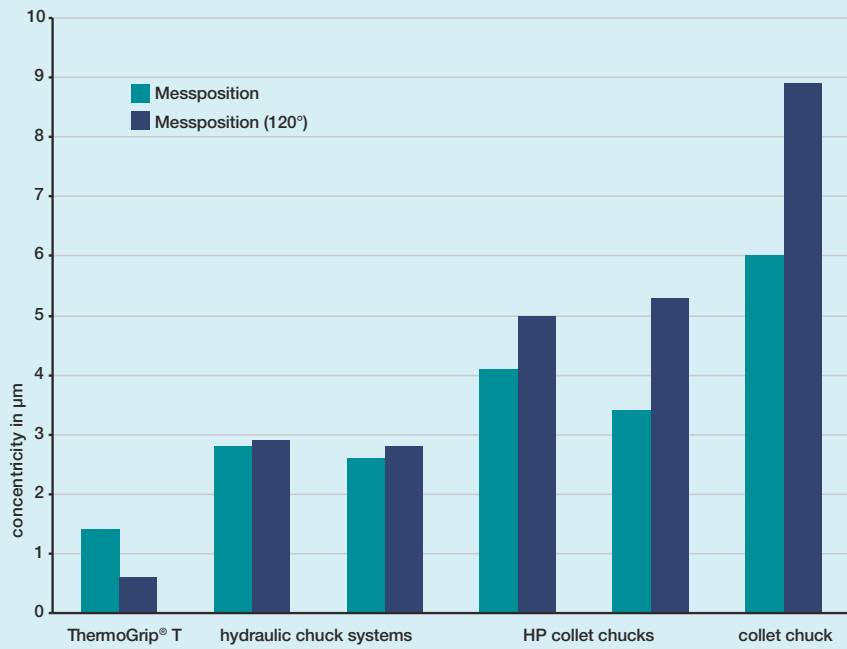

INDUCTION COIL TECHNOLOGY

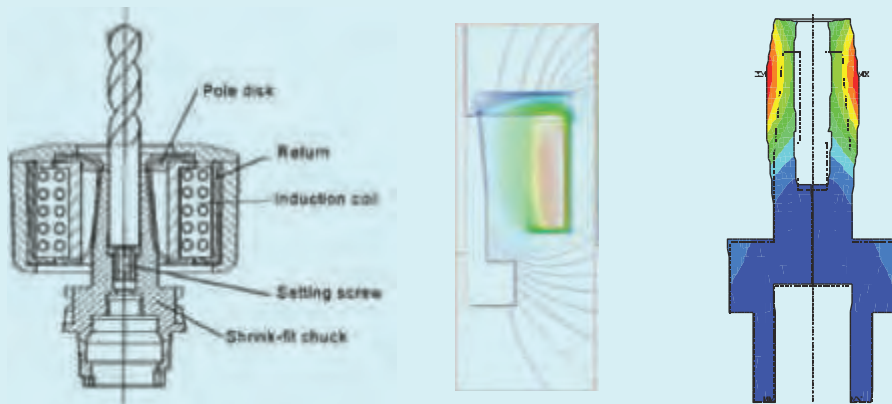

LIQUID EMULSION SYSTEM

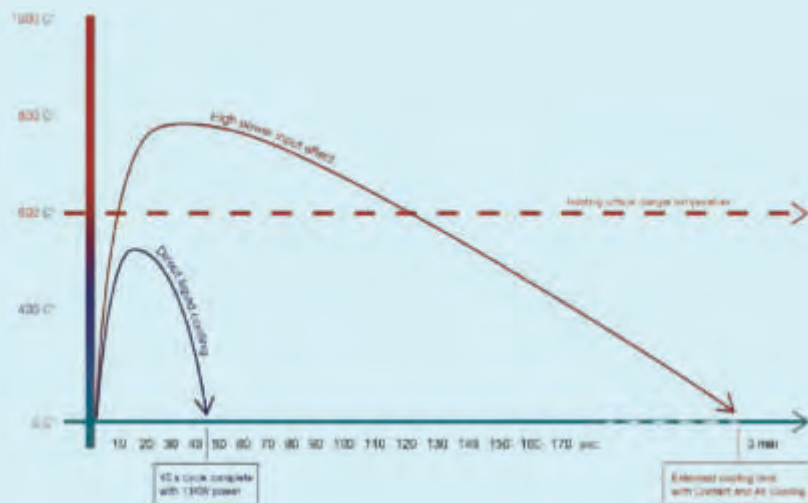

"EVERY DAY, THE WORLD SHRINKS A LITTLE MORE."

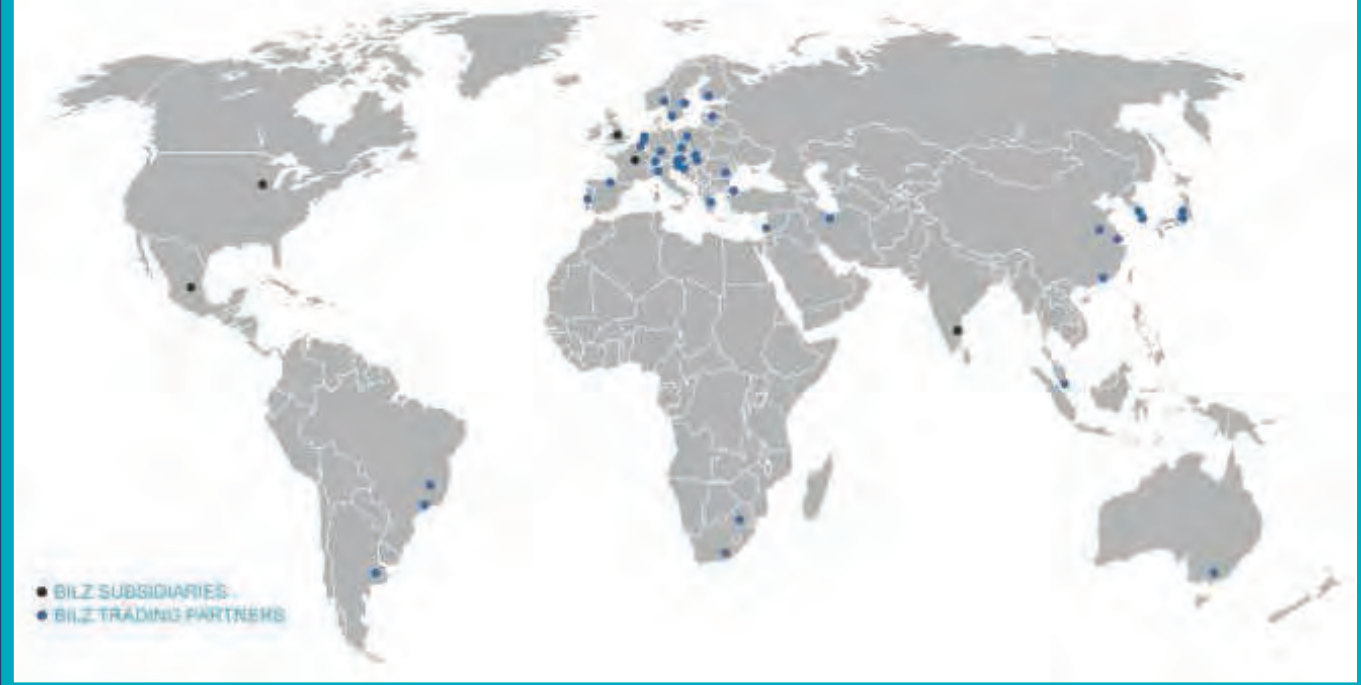

# BILZ

## We'll Take You Where You Need to Go.

All of our products are "best in class" technologies that help our customers remain competitive and profitable. We have something that can help you too! Learn more at [www.bilzusa.com](http://www.bilzusa.com).

### **The Latest Technology. The Best Quality. Extensive Product Support.**

**We hold our promise in three important ways:** First, by delivering the most advanced tool clamping technology available; Second, by maintaining the highest level of quality; Third, by providing the strongest product, application and engineering support in the industry. **Let us prove it! Bilz Tool Company, Inc.**

[www.bilzusa.com](http://www.bilzusa.com) | 1140 N. Main Street | Lombard, IL 60148 | **847-734-9390**